

Microwave Switches Selection Guide

Failsafe



SPDT

Latching



High Power



DC to 40 GHz



Transfer



Low PIM



TELEDYNE
COAX SWITCHES
Everywhere you look™



RoHS or Non-RoHS:
Your Choice!



TELEDYNE
COAX SWITCHES
Everywhere you look™

teledynecoax.com

Switching Solutions

Industry Leader

With over 50 years experience, Teledyne is the world's innovative leader in manufacturing ultraminiature, hermetically sealed, electromechanical and solid-state switching products. Our comprehensive product line meets a wide range of requirements for industrial, commercial, medical, RF & wireless, defense and aerospace applications.

Product Assurance

Under an aggressive Total Quality Management (TQM) program, Teledyne has embraced a "continuous improvement" culture. With recognized certifications such as Boeing D6-82479, MIL-STD-790, AS/EN/JISQ9100:2009 (Rev C) and ISO 9001:2008, Teledyne has become a primary supplier of switching solutions with the highest quality and reliability to industry leaders around the world.

Product Development

Teledyne offers a full range of comprehensive switching solutions. In addition to offering standard switching solutions, our experienced team works closely with our customers to develop tailored products for specific applications. We offer advanced engineering, state-of-the-art manufacturing techniques, and over 50 years of switching experience with a commitment to quality, costs and delivery.

Standard & Custom Matrix Assemblies

Teledyne offers a wide variety of RF matrix assemblies. Incorporating highly repeatable and long-cycle-life relays and switches, our matrices cover the spectrum from DC to 40GHz.

Teledyne's modular approach to building matrices allows assembly of a vast array of customized matrices with the same standard subassemblies. The internal components utilize Teledyne's proven switches. Our universal programmable microcontroller can be used for any matrix configuration. The universal power supply allows the matrix assembly to be used worldwide.

Low PIM Switches

Teledyne offers coaxial switches that have extremely low passive intermodulation for use in narrow bandwidth communication applications. The low PIM switches come in a variety of configurations, such as, SPDT, Transfer and Multi-Throws.

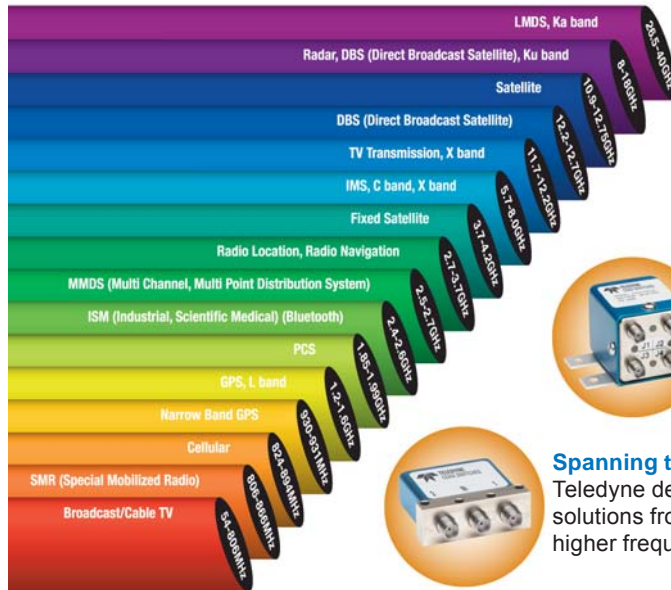

Spanning the Spectrum — Teledyne delivers switching solutions from DC to 40 GHz, with higher frequencies in development.

Featured switching solutions include:



Microwave Switch Matrix Assemblies

- Multiple standard and customized configurations
- Universal Power Supply
- Visual Display – LCD
- Standard and custom chassis available



CCR-40K DC–40 GHz SPDT Switch

- Excellent insertion loss repeatability
- Ultra low passive intermodulation (PIM)
- Characterized at 5 million cycles
- Compact design with 40 GHz performance



Matrix Assemblies — Teledyne provides matrix assemblies, such as the Model CSM-0003 1x40 Switch Matrix, that incorporate coaxial switches.

Space-Qualified Switches

Teledyne's space-qualified coaxial switches are typically custom-designed and manufactured according to specific performance requirements. We also provide a complete line of standard, off-the-shelf switches that offer customers significant cost savings, while satisfying most typical requirements for scientific, meteorological and communication satellite applications.

Technical Service & Customer Support

Teledyne provides easy access to technical service and customer support. Our website makes it easy to find technical information, buy products and even get e-mail responses within 24 hours. Switching solutions are only a mouse click away at www.teledynecoax.com.

Space-Qualified Switches



- Wide range of screening options available
- Custom designs to suit any application
- Proven heritage in space

(800) 351-7368

www.teledynecoax.com

TABLE OF CONTENTS

SERIES OVERVIEW	2-15
PART NUMBERING SYSTEM	16
SPDT SWITCHES	17-27
2P3T SWITCHES	28-29
TRANSFER SWITCHES	30-33
MULTI-THROW SWITCHES.....	34-41
LOW PIM SWITCHES	42-50
3-STATE ATTENUATED SWITCHES	51
TELEDYNE COAX SWITCH PERFORMANCE (<i>POWER VS. FREQ, IL REPEATABILITY</i>)	52-53
GLOSSARY	54-55
SWITCH MATRIX	56-58
MINI MATRIX BOX.....	59-62
RF121 / GRF121 ELECTROMECHANICAL RELAY	63
OTHER TELEDYNE PRODUCTS (<i>EMR, COAX, ISSR, MSSR, MATRIX, SPACE</i>)	64-69

Mini Matrix	RF121 / GRF121 (Electromechanical Relay)	
<ul style="list-style-type: none"> • USB only or USB & Ethernet Control • Terminated or Non-Terminated • Failsafe or Latching • Various Connectors • DC-40 GHz • 5,000,000 cycles • 5.08" Wide, 2.17 High, 7.75" Depth 	<ul style="list-style-type: none"> • Broader bandwidth (DC - 16GHz) • Excellent Signal integrity up to 40Gbps • SPDT, Magnetic Latching • Hermetically Sealed • Metal Enclosure for EMI shielding • High Repeatability • 3 Million Cycle Life 	
 <p data-bbox="412 1864 570 1892">MMC Series</p> <p data-bbox="444 1906 537 1927">See Page 59</p>	 <p data-bbox="971 1864 1047 1892">RF121</p> <p data-bbox="964 1906 1057 1927">See Page 63</p> <p data-bbox="1305 1864 1398 1892">GRF121</p> <p data-bbox="1305 1906 1398 1927">See Page 63</p>	



RoHS or Non-RoHS:
Your Choice!



Series (Commercial/Elite)		CCR-33/CR-33	CCR-53/CR-53	CCR-33K/CR-33K	CCR-40K/CR-40K
Configuration		SPDT	SPDT	SPDT	SPDT
Switch Function		Failsafe or Latching	Failsafe or Latching	Failsafe or Latching	Failsafe or Latching
Frequency	Commercial Model Elite Model	DC to 18 GHz DC to 22 GHz	DC to 26.5 GHz DC to 26.5 GHz	DC to 33.5 GHz DC to 33.5 GHz	DC to 40 GHz DC to 40 GHz
Coil Voltages Available		12, 15, 24, 28	12, 15, 24, 28	12, 15, 24, 28	12, 15, 24, 28
Connectors Available		SMA	SMA	2.92mm	2.92mm
Temperature Range	Commercial Model Elite Model	-40°C to +65°C -55°C to +85°C	-40°C to +65°C -55°C to +85°C	-40°C to +65°C -55°C to +85°C	-40°C to +65°C -55°C to +85°C
Special Features		Compact Package	High Frequency Performance	High Frequency Performance	High Frequency Performance
Typical Contact Life		5,000,000 cycles	5,000,000 cycles	5,000,000 cycles	5,000,000 cycles
Switch with Indicator Contacts		1,000,000 cycles	1,000,000 cycles	1,000,000 cycles	1,000,000 cycles
Typical RF Performance	VSWR (max)	DC-6 GHz : 1.10:1 6-12 GHz : 1.10:1 12-14 GHz : 1.20:1 14-18 GHz : 1.20:1	DC-4 GHz : 1.10:1 4-8 GHz : 1.10:1 8-12 GHz : 1.10:1 12-16 GHz : 1.20:1 16-20 GHz : 1.20:1 20-26.5 GHz : 1.30:1	DC-6 GHz : 1.10:1 6-12 GHz : 1.10:1 12-18 GHz : 1.20:1 18-24 GHz : 1.30:1 24-30 GHz : 1.40:1 30-33.5 GHz : 1.70:1	DC-6 GHz : 1.25:1 6-12 GHz : 1.40:1 12-18 GHz : 1.50:1 18-27 GHz : 1.60:1 27-34 GHz : 1.80:1 34-40 GHz : 1.80:1
	Insertion Loss (max)	DC-6 GHz : 0.10 dB 6-12 GHz : 0.10 dB 12-14 GHz : 0.20 dB 14-18 GHz : 0.30 dB	DC-4 GHz : 0.20 dB 4-8 GHz : 0.20 dB 8-12 GHz : 0.20 dB 12-16 GHz : 0.30 dB 16-20 GHz : 0.40 dB 20-26.5 GHz : 0.40 dB	DC-6 GHz : 0.20 dB 6-12 GHz : 0.20 dB 12-18 GHz : 0.30 dB 18-24 GHz : 0.40 dB 24-30 GHz : 0.40 dB 30-33.5 GHz : 0.70 dB	DC-6 GHz : 0.20 dB 6-12 GHz : 0.40 dB 12-18 GHz : 0.50 dB 18-27 GHz : 0.60 dB 27-34 GHz : 0.70 dB 34-40 GHz : 0.80 dB
	Isolation (min)	DC-6 GHz : 90 dB 6-12 GHz : 80 dB 12-14 GHz : 80 dB 14-18 GHz : 70 dB	DC-4 GHz : 90 dB 4-8 GHz : 90 dB 8-12 GHz : 80 dB 12-16 GHz : 75 dB 16-20 GHz : 65 dB 20-26.5 GHz : 50 dB	DC-6 GHz : 80 dB 6-12 GHz : 75 dB 12-18 GHz : 75 dB 18-24 GHz : 70 dB 24-30 GHz : 70 dB 30-33.5 GHz : 50 dB	DC-6 GHz : 70 dB 6-12 GHz : 60 dB 12-18 GHz : 60 dB 18-27 GHz : 50 dB 27-34 GHz : 50 dB 34-40 GHz : 50 dB
Options	Self Cutoff (Latching Only)	✓	✓	✓	✓
	Indicator Contacts	✓	✓	✓	✓
	Self Cutoff and Indicator Contacts (Latching Only)	✓	✓	✓	✓
	TTL Interface	✓	✓	✓	✓
	TTL Decoder	—	—	—	—
	Moisture Seal	✓	✓	✓	✓
	Narrow Body	✓	✓	✓	✓
	Coil Transient Suppression Diodes and Polarity Protection Diode	✓	✓	✓	✓
Sub-D Connector	✓	✓	✓	✓	
Typical Mechanical Outline		1.50 x 1.80 x .52 in. 38.1 x 45.7 x 13.2 mm See Page 20	1.50 x 1.80 x .52 in. 38.1 x 45.7 x 13.2 mm See Page 20	1.50 x 1.80 x .52 in. 38.1 x 45.7 x 13.2 mm See Page 20	1.50 x 1.82 x .52 in. 38.1 x 46.2 x 13.2 mm See Page 20



Series (Commercial/Elite)		CCRT-33/CRT-33	CCRT-53/CRT-53	CCR-33M/CR-33M	CCS-32/CS-32
Configuration		SPDT	SPDT	SPDT	SPDT
Switch Function		Failsafe or Latching	Failsafe or Latching	Failsafe or Latching	Failsafe or Latching
Frequency	Commercial Model Elite Model	DC to 18 GHz DC to 22 GHz	DC to 26.5 GHz DC to 26.5 GHz	DC to 3 GHz DC to 3 GHz	DC to 12 GHz DC to 12 GHz
Coil Voltages Available		12, 15, 24, 28	12, 15, 24, 28	12, 15, 24, 28	12, 15, 24, 28
Connectors Available		SMA	SMA	Mini-SMB	N, TNC
Temperature Range	Commercial Model Elite Model	-40°C to +65°C -55°C to +85°C	-40°C to +65°C -55°C to +85°C	-40°C to +65°C -55°C to +85°C	-40°C to +65°C -55°C to +85°C
Special Features		50-Ohm Internal Termination	50-Ohm Internal Termination	75-Ohm Impedance	High RF Power Handling
Typical Contact Life Switch with Indicator Contacts		5,000,000 cycles 1,000,000 cycles	5,000,000 cycles 1,000,000 cycles	5,000,000 cycles 1,000,000 cycles	3,000,000 cycles 1,000,000 cycles
Typical RF Performance	VSWR (max)	DC-7 GHz : 1.10:1 7-12 GHz : 1.20:1 12-15 GHz : 1.40:1 15-18 GHz : 1.40:1	DC-6 GHz : 1.10:1 6-12 GHz : 1.20:1 12-18 GHz : 1.30:1 18-22 GHz : 1.50:1 22-26.5 GHz : 1.60:1	DC-1 GHz : 1.10:1 1-2 GHz : 1.20:1 2-3 GHz : 1.30:1	DC-3 GHz : 1.10:1 3-6 GHz : 1.20:1 6-9 GHz : 1.30:1 9-12 GHz : 1.40:1
	Insertion Loss (max)	DC-7 GHz : 0.10 dB 7-12 GHz : 0.20 dB 12-15 GHz : 0.20 dB 15-18 GHz : 0.30 dB	DC-6 GHz : 0.20 dB 6-12 GHz : 0.20 dB 12-18 GHz : 0.40 dB 18-22 GHz : 0.50 dB 22-26.5 GHz : 0.50 dB	DC-1 GHz : 0.10 dB 1-2 GHz : 0.20 dB 2-3 GHz : 0.20 dB	DC-3 GHz : 0.10 dB 3-6 GHz : 0.20 dB 6-9 GHz : 0.30 dB 9-12 GHz : 0.30 dB
	Isolation (min)	DC-7 GHz : 70 dB 7-12 GHz : 70 dB 12-15 GHz : 60 dB 15-18 GHz : 60 dB	DC-6 GHz : 80 dB 6-12 GHz : 80 dB 12-18 GHz : 70 dB 18-22 GHz : 70 dB 22-26.5 GHz : 55 dB	DC-1 GHz : 60 dB 1-2 GHz : 60 dB 2-3 GHz : 60 dB	DC-3 GHz : 70 dB 3-6 GHz : 70 dB 6-9 GHz : 65 dB 9-12 GHz : 65 dB
Options	Self Cutoff (Latching Only)	✓	✓	✓	✓
	Indicator Contacts	✓	✓	✓	✓
	Self Cutoff and Indicator Contacts (Latching Only)	✓	✓	✓	✓
	TTL Interface	✓	✓	✓	✓
	TTL Decoder	—	—	—	—
	Moisture Seal	✓	✓	✓	✓
	Narrow Body	—	—	✓	—
	Coil Transient Suppression Diodes and Polarity Protection Diode	✓	✓	✓	✓
	Sub-D Connector	✓	✓	✓	✓
Typical Mechanical Outline		2.06 x 2.05 x .56 in. 52.3 x 52.1 x 14.2 mm See Page 24	2.06 x 2.05 x .56 in. 52.3 x 52.1 x 14.2 mm See Page 24	1.50 x 1.80 x .52 in. 38.1 x 45.7 x 13.2 mm See Page 26	2.75 x 2.30 x .90 in. 69.9 x 58.4 x 22.9 mm See Page 28



RoHS or Non-RoHS:
Your Choice!



Series (Commercial/Elite)		CCRS-33/CRS-33	CCRS-53/CRS-53	CCS-37/CS-37	CCS-47/CS-47
Configuration		2P3T	2P3T	Transfer Switch	Transfer Switch
Switch Function		Failsafe or Latching	Failsafe or Latching	Failsafe or Latching	Failsafe or Latching
Frequency	Commercial Model Elite Model	DC to 18 GHz DC to 18 GHz	DC to 26.5 GHz DC to 26.5 GHz	DC to 18 GHz DC to 18 GHz	DC to 12 GHz DC to 12 GHz
Coil Voltages Available		12, 15, 24, 28	12, 15, 24, 28	12, 15, 24, 28	12, 15, 24, 28
Connectors Available		SMA	SMA	SMA	TNC, N
Temperature Range	Commercial Model Elite Model	-40°C to +65°C -55°C to +85°C	-40°C to +65°C -55°C to +85°C	-40°C to +65°C -55°C to +85°C	-40°C to +65°C -55°C to +85°C
Special Features		Multiport	High Frequency Multiport	Compact Package	High RF Power Handling
Typical Contact Life Switch with Indicator Contacts		5,000,000 cycles 1,000,000 cycles	5,000,000 cycles 1,000,000 cycles	5,000,000 cycles 1,000,000 cycles	3,000,000 cycles 1,000,000 cycles
Typical RF Performance	VSWR (max)	DC-7 GHz : 1.10:1 7-12 GHz : 1.20:1 12-15 GHz : 1.30:1 15-18 GHz : 1.30:1	DC-6 GHz : 1.10:1 6-12 GHz : 1.20:1 12-18 GHz : 1.20:1 18-22 GHz : 1.40:1 22-26.5 GHz : 1.50:1	DC-5 GHz : 1.10:1 5-10 GHz : 1.20:1 10-13 GHz : 1.30:1 13-15 GHz : 1.60:1 15-18 GHz : 1.60:1	DC-2 GHz : 1.20:1 2-5 GHz : 1.20:1 5-8 GHz : 1.30:1 8-10 GHz : 1.50:1 10-12 GHz : 1.50:1
	Insertion Loss (max)	DC-7 GHz : 0.10 dB 7-12 GHz : 0.10 dB 12-15 GHz : 0.20 dB 15-18 GHz : 0.20 dB	DC-6 GHz : 0.10 dB 6-12 GHz : 0.20 dB 12-18 GHz : 0.30 dB 18-22 GHz : 0.40 dB 22-26.5 GHz : 0.60 dB	DC-5 GHz : 0.10 dB 5-10 GHz : 0.20 dB 10-13 GHz : 0.20 dB 13-15 GHz : 0.50 dB 15-18 GHz : 0.50 dB	DC-2 GHz : 0.10 dB 2-5 GHz : 0.20 dB 5-8 GHz : 0.20 dB 8-10 GHz : 0.40 dB 10-12 GHz : 0.40 dB
	Isolation (min)	DC-7 GHz : 70 dB 7-12 GHz : 70 dB 12-15 GHz : 65 dB 12-18 GHz : 65 dB	DC-6 GHz : 80 dB 6-12 GHz : 75 dB 12-18 GHz : 75 dB 18-22 GHz : 70 dB 22-26.5 GHz : 60 dB	DC-5 GHz : 80 dB 5-10 GHz : 80 dB 10-13 GHz : 80 dB 13-15 GHz : 80 dB 15-18 GHz : 80 dB	DC-2 GHz : 70 dB 2-5 GHz : 70 dB 5-8 GHz : 70 dB 8-10 GHz : 60 dB 10-12 GHz : 60 dB
Options	Self Cutoff (Latching Only)	✓	✓	✓	✓
	Indicator Contacts	✓	✓	✓	✓
	Self Cutoff and Indicator Contacts (Latching Only)	✓	✓	✓	✓
	TTL Interface	✓	✓	✓	✓
	TTL Decoder	—	—	—	—
	Moisture Seal	✓	✓	✓	✓
	Narrow Body	—	—	—	—
	Coil Transient Suppression Diodes and Polarity Protection Diode	✓	✓	✓	✓
Sub-D Connector	✓	✓	✓	✓	
Typical Mechanical Outline		2.06 x 1.90 x .56 in. 52.3 x 48.3 x 14.2 mm See Page 30	2.06 x 1.90 x .56 in. 52.3 x 48.3 x 14.2 mm See Page 30	2.19 x 2.00 x 1.37 in. 55.6 x 50.8 x 34.8 mm See Page 32	3.12 x 2.60 x 1.81 in. 79.2 x 66.1 x 46 mm See Page 34

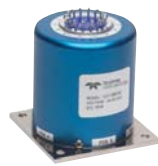

Series (Commercial/Elite)		CCR-48K/CR-48K	CCR-38/CR-38	CCR-38	CCR-38
Configuration		SP3T to SP6T	SP3T to SP6T	SP7T to SP8T	SP9T to SP10T
Switch Function		Normally Open	Normally Open	Normally Open	Normally Open
Frequency	Commercial Model Elite Model	DC to 40 GHz DC to 40 GHz	DC to 18 GHz DC to 22 GHz	DC to 12 GHz -	DC to 12 GHz -
Coil Voltages Available		12, 15, 24, 28	12, 15, 24, 28	12, 15, 24, 28	12, 15, 24, 28
Connectors Available		2.92mm	SMA	SMA	SMA
Temperature Range	Commercial Model Elite Model	-40°C to +65°C -55°C to +85°C	-40°C to +65°C -55°C to +85°C	-40°C to +65°C -	-40°C to +65°C -
Special Features		Multi-throw	Multi-throw	Multi-throw	Multi-throw
Typical Contact Life		5,000,000 cycles	5,000,000 cycles	3,000,000 cycles	3,000,000 cycles
Switch with Indicator Contacts		1,000,000 cycles	1,000,000 cycles	1,000,000 cycles	1,000,000 cycles
Typical RF Performance	VSWR (max)	DC-6 GHz : 1.10:1 6-12 GHz : 1.25:1 12-18 GHz : 1.35:1 18-28 GHz : 1.70:1 28-34 GHz : 1.70:1 34-40 GHz : 2.10:1	DC-4 GHz : 1.05:1 4-8 GHz : 1.10:1 8-12 GHz : 1.20:1 12-16 GHz : 1.20:1 16-20 GHz : 1.20:1 20-22 GHz : 1.20:1	DC-2.3 GHz : 1.15:1 2.3-3 GHz : 1.20:1 3-8 GHz : 1.30:1 8-12.4 GHz : 1.40:1	DC-2.3 GHz : 1.15:1 2.3-3 GHz : 1.20:1 3-6 GHz : 1.30:1 6-8 GHz : 1.40:1 8-10 GHz : 1.60:1
	Insertion Loss (max)	DC-6 GHz : 0.20 dB 6-12 GHz : 0.30 dB 12-18 GHz : 0.40 dB 18-28 GHz : 0.70 dB 28-34 GHz : 0.80 dB 34-40 GHz : 1.10 dB	DC-4 GHz : 0.10 dB 4-8 GHz : 0.20 dB 8-12 GHz : 0.20 dB 12-16 GHz : 0.30 dB 16-20 GHz : 0.30 dB 20-22 GHz : 0.30 dB	DC-2.3 GHz : 0.20 dB 2.3-3 GHz : 0.25 dB 3-8 GHz : 0.30 dB 8-12.4 GHz : 0.40 dB	DC-2.3 GHz : 0.20 dB 2.3-3 GHz : 0.25 dB 3-6 GHz : 0.30 dB 6-8 GHz : 0.40 dB 8-10 GHz : 0.60 dB
	Isolation (min)	DC-6 GHz : 90 dB 6-12 GHz : 80 dB 12-18 GHz : 75 dB 18-28 GHz : 75 dB 28-34 GHz : 70 dB 34-40 GHz : 70 dB	DC-4 GHz : 80 dB 4-8 GHz : 80 dB 8-12 GHz : 80 dB 12-16 GHz : 80 dB 16-20 GHz : 75 dB 20-22 GHz : 75 dB	DC-2.3 GHz : 80 dB 2.3-3 GHz : 70 dB 3-8 GHz : 65 dB 8-12.4 GHz : 60 dB	DC-2.3 GHz : 80 dB 2.3-3 GHz : 70 dB 3-6 GHz : 65 dB 6-8 GHz : 60 dB 8-10 GHz : 60 dB
Options	Self Cutoff (Latching Only)	—	—	—	—
	Indicator Contacts	✓	✓	✓	✓
	Self Cutoff and Indicator Contacts (Latching Only)	—	—	—	—
	TTL Interface	✓	✓	✓	✓
	TTL Decoder	—	✓	✓	✓
	Moisture Seal	✓	✓	✓	✓
	Narrow Body	—	—	—	—
	Coil Transient Suppression Diodes and Polarity Protection Diode	✓	✓	✓	✓
Sub-D Connector	✓	✓	✓	✓	
Typical Mechanical Outline		1.75 x 2.27 x 1.75 in. 44.5 x 57.7 x 44.5 mm See Page 36	1.75 x 2.27 x 1.75 in. 44.5 x 57.7 x 44.5 mm See Page 36	2.50 x 2.87 x 2.50 in. 63.5 x 72.9 x 63.5 mm See Page 38	3.10 x 2.77 x 3.10 in. 78.7 x 70.4 x 78.7 mm See Page 38



RoHS or Non-RoHS:
Your Choice!



Series (Commercial/Elite)		CCR-58/CR-58	CCR-58	CCT-38/CT-38	CCT-38
Configuration		SP3T to SP6T	SP7T to SP8T	SP3T to SP6T	SP7T to SP8T
Switch Function		Normally Open	Normally Open	Normally Open	Normally Open
Frequency	Commercial Model Elite Model	DC to 26.5 GHz DC to 26.5 GHz	DC to 18 GHz -	DC to 18 GHz DC to 22 GHz	DC to 12 GHz -
Coil Voltages Available		12, 15, 24, 28	12, 15, 24, 28	12, 15, 24, 28	12, 15, 24, 28
Connectors Available		SMA	SMA	SMA	SMA
Temperature Range	Commercial Model Elite Model	-40°C to +65°C -55°C to +85°C	-40°C to +65°C -	-40°C to +65°C -55°C to +85°C	-40°C to +65°C -
Special Features		High Frequency Multi-throw	Multi-throw	50-Ohm Internal Termination	50-Ohm Internal Termination
Typical Contact Life Switch with Indicator Contacts		5,000,000 cycles 1,000,000 cycles	3,000,000 cycles 1,000,000 cycles	5,000,000 cycles 1,000,000 cycles	3,000,000 cycles 1,000,000 cycles
Typical RF Performance	VSWR (max)	DC-4 GHz : 1.05:1 4-8 GHz : 1.10:1 8-12 GHz : 1.20:1 12-16 GHz : 1.20:1 16-20 GHz : 1.20:1 20-22 GHz : 1.20:1	DC-3 GHz : 1.30:1 3-6 GHz : 1.30:1 6-12 GHz : 1.40:1 12-18 GHz : 1.60:1	DC-4 GHz : 1.05:1 4-8 GHz : 1.10:1 8-12 GHz : 1.20:1 12-16 GHz : 1.20:1 16-20 GHz : 1.20:1 20-22 GHz : 1.20:1	DC-2.3 GHz : 1.15:1 2.3-3 GHz : 1.20:1 3-8 GHz : 1.30:1 8-12.4 GHz : 1.40:1
	Insertion Loss (max)	DC-4 GHz : 0.10 dB 4-8 GHz : 0.20 dB 8-12 GHz : 0.20 dB 12-16 GHz : 0.30 dB 16-20 GHz : 0.30 dB 20-22 GHz : 0.30 dB	DC-3 GHz : 0.20 dB 3-6 GHz : 0.20 dB 6-12 GHz : 0.40 dB 12-18 GHz : 0.50 dB	DC-4 GHz : 0.10 dB 4-8 GHz : 0.20 dB 8-12 GHz : 0.20 dB 12-16 GHz : 0.30 dB 16-20 GHz : 0.30 dB 20-22 GHz : 0.30 dB	DC-2.3 GHz : 0.20 dB 2.3-3 GHz : 0.25 dB 3-8 GHz : 0.30 dB 8-12.4 GHz : 0.40 dB
	Isolation (min)	DC-4 GHz : 80 dB 4-8 GHz : 80 dB 8-12 GHz : 80 dB 12-16 GHz : 80 dB 16-20 GHz : 75 dB 20-22 GHz : 75 dB	DC-3 GHz : 70 dB 3-6 GHz : 70 dB 6-12 GHz : 60 dB 12-18 GHz : 60 dB	DC-4 GHz : 80 dB 4-8 GHz : 80 dB 8-12 GHz : 80 dB 12-16 GHz : 80 dB 16-20 GHz : 75 dB 20-22 GHz : 75 dB	DC-2.3 GHz : 80 dB 2.3-3 GHz : 70 dB 3-8 GHz : 65 dB 8-12.4 GHz : 60 dB
Options	Self Cutoff (Latching Only)	—	—	—	—
	Indicator Contacts	✓	✓	✓	✓
	Self Cutoff and Indicator Contacts (Latching Only)	—	—	—	—
	TTL Interface	✓	✓	✓	✓
	TTL Decoder	✓	✓	✓	✓
	Moisture Seal	✓	✓	✓	✓
	Narrow Body	—	—	—	—
	Coil Transient Suppression Diodes and Polarity Protection Diode	✓	✓	✓	✓
Sub-D Connector	✓	✓	✓	✓	
Typical Mechanical Outline		1.75 x 2.50 x 1.75 in. 44.5 x 63.5 x 44.5 mm See Page 36	2.50 x 2.87 x 2.50 in. 63.5 x 72.9 x 63.5 mm See Page 36	2.25 x 2.50 x 2.25 in. 57.2 x 63.5 x 57.2 mm See Page 36	2.50 x 2.87 x 2.50 in. 63.5 x 72.9 x 63.5 mm See Page 38



Series (Commercial/Elite)		CCT-38	CCT-58/CT-58	CCT-58
Configuration		SP9T to SP10T	SP3T to SP6T	SP7T to SP8T
Switch Function		Normally Open	Normally Open	Normally Open
Frequency	Commercial Model	DC to 12 GHz	DC to 26.5 GHz	DC to 18 GHz
	Elite Model	-	DC to 26.5 GHz	-
Coil Voltages Available		12, 15, 24, 28	12, 15, 24, 28	12, 15, 24, 28
Connectors Available		SMA	SMA	SMA
Temperature Range	Commercial Model	-40°C to +65°C	-40°C to +65°C	-40°C to +65°C
	Elite Model	-	-55°C to +85°C	-
Special Features		50-Ohm Internal Termination	50-Ohm Internal Termination	50-Ohm Internal Termination
Typical Contact Life		3,000,000 cycles	5,000,000 cycles	3,000,000 cycles
Switch with Indicator Contacts		1,000,000 cycles	1,000,000 cycles	1,000,000 cycles
Typical RF Performance	VSWR (max)	DC-2.3 GHz : 1.15:1 2.3-3 GHz : 1.20:1 3-6 GHz : 1.30:1 6-8 GHz : 1.40:1 8-10 GHz : 1.60:1	DC-4 GHz : 1.05:1 4-8 GHz : 1.10:1 8-12 GHz : 1.20:1 12-16 GHz : 1.20:1 16-20 GHz : 1.20:1 20-22 GHz : 1.20:1	DC-3 GHz : 1.30:1 3-6 GHz : 1.30:1 6-12 GHz : 1.40:1 12-18 GHz : 1.60:1
	Insertion Loss (max)	DC-2.3 GHz : 0.20 dB 2.3-3 GHz : 0.25 dB 3-6 GHz : 0.30 dB 6-8 GHz : 0.40 dB 8-10 GHz : 0.60 dB	DC-4 GHz : 0.10 dB 4-8 GHz : 0.20 dB 8-12 GHz : 0.20 dB 12-16 GHz : 0.30 dB 16-20 GHz : 0.30 dB 20-22 GHz : 0.30 dB	DC-3 GHz : 0.20 dB 3-6 GHz : 0.20 dB 6-12 GHz : 0.40 dB 12-18 GHz : 0.50 dB
	Isolation (min)	DC-2.3 GHz : 80 dB 2.3-3 GHz : 70 dB 3-6 GHz : 65 dB 6-8 GHz : 60 dB 8-10 GHz : 60 dB	DC-4 GHz : 80 dB 4-8 GHz : 80 dB 8-12 GHz : 80 dB 12-16 GHz : 80 dB 16-20 GHz : 75 dB 20-22 GHz : 75 dB	DC-3 GHz : 70 dB 3-6 GHz : 70 dB 6-12 GHz : 60 dB 12-18 GHz : 60 dB
Options	Self Cutoff (Latching Only)	—	—	—
	Indicator Contacts	✓	✓	✓
	Self Cutoff and Indicator Contacts (Latching Only)	—	—	—
	TTL Interface	✓	✓	✓
	TTL Decoder	✓	✓	✓
	Moisture Seal	✓	✓	✓
	Narrow Body	—	—	—
	Coil Transient Suppression Diodes and Polarity Protection Diode	✓	✓	✓
Sub-D Connector	✓	✓	✓	
Typical Mechanical Outline		3.10 x 2.77 x 3.10 in. 78.7 x 70.4 x 78.7 mm See Page 38	2.25 x 2.50 x 2.25 in. 57.2 x 63.5 x 57.2 mm See Page 36	2.50 x 2.87 x 2.50 in. 63.5 x 72.9 x 63.5 mm



RoHS or Non-RoHS:
Your Choice!



Series (Commercial/Elite)		CCT-49K/CT-49K	CCR-39/CR-39	CCR-39
Configuration		SP3T to SP6T	SP3T to SP6T	SP7T to SP8T
Switch Function		Latching	Latching	Latching
Frequency	Commercial Model Elite Model	DC to 40 GHz DC to 40 GHz	DC to 18 GHz DC to 22 GHz	DC to 12 GHz -
Coil Voltages Available		12, 15, 24, 28	12, 15, 24, 28	12, 15, 24, 28
Connectors Available		2.92mm	SMA	SMA
Temperature Range	Commercial Model Elite Model	-40°C to +65°C -55°C to +85°C	-40°C to +65°C -55°C to +85°C	-40°C to +65°C
Special Features		Multi-throw	Multi-throw	Multi-throw
Typical Contact Life		5,000,000 cycles	5,000,000 cycles	3,000,000 cycles
Switch with Indicator Contacts		1,000,000 cycles	1,000,000 cycles	1,000,000 cycles
Typical RF Performance	VSWR (max)	DC-6 GHz : 1.25:1 6-12 GHz : 1.25:1 12-18 GHz : 1.50:1 18-28 GHz : 1.20:1 28-36 GHz : 1.20:1 36-40 GHz : 1.20:1	DC-4 GHz : 1.05:1 4-8 GHz : 1.10:1 8-12 GHz : 1.20:1 12-16 GHz : 1.20:1 16-20 GHz : 1.20:1 20-22 GHz : 1.20:1	DC-6 GHz : 1.10:1 6-12 GHz : 1.25:1
	Insertion Loss (max)	DC-6 GHz : 0.20 dB 6-12 GHz : 0.20 dB 12-18 GHz : 0.40 dB 18-28 GHz : 0.50 dB 28-36 GHz : 1.0 dB 36-40 GHz : 1.40 dB	DC-4 GHz : 0.10 dB 4-8 GHz : 0.20 dB 8-12 GHz : 0.20 dB 12-16 GHz : 0.30 dB 16-20 GHz : 0.30 dB 20-22 GHz : 0.30 dB	DC-6 GHz : 0.10 dB 6-12 GHz : 0.20 dB
	Isolation (min)	DC-6 GHz : 75 dB 6-12 GHz : 75 dB 12-18 GHz : 70 dB 18-28 GHz : 70 dB 28-36 GHz : 60 dB 36-40 GHz : 60 dB	DC-4 GHz : 80 dB 4-8 GHz : 80 dB 8-12 GHz : 80 dB 12-16 GHz : 80 dB 16-20 GHz : 75 dB 20-22 GHz : 75 dB	DC-6 GHz : 80 dB 6-12 GHz : 80 dB
Options	Self Cutoff (Latching Only)	✓	✓	✓
	Indicator Contacts	✓	✓	✓
	Self Cutoff and Indicator Contacts (Latching Only)	✓	✓	✓
	TTL Interface	✓	✓	✓
	TTL Decoder	✓	✓	✓
	Moisture Seal	✓	✓	✓
	Narrow Body	—	—	—
	Coil Transient Suppression Diodes and Polarity Protection Diode	✓	✓	✓
Sub-D Connector	✓	✓	✓	
Typical Mechanical Outline		2.25 x 2.50 x 2.25 in. 57.2 x 63.5 x 57.2 mm See Page 36	2.25 x 2.50 x 2.25 in. 57.2 x 63.5 x 57.2 mm See Page 36	2.50 x 2.87 x 2.50 in. 63.5 x 72.9 x 63.5 mm See Page 39



Series (Commercial/Elite)		CCR-39	CCR-59/CR-59	CCR-59	CCR-59
Configuration		SP9T to SP10T	SP3T to SP6T	SP7T to SP8T	SP9T to SP10T
Switch Function		Latching	Latching	Latching	Latching
Frequency	Commercial Model Elite Model	DC to 12 GHz	DC to 26.5 GHz DC to 26.5 GHz	DC to 18 GHz	DC to 18 GHz
Coil Voltages Available		12, 15, 24, 28	12, 15, 24, 28	12, 15, 24, 28	12, 15, 24, 28
Connectors Available		SMA	SMA	SMA	SMA
Temperature Range	Commercial Model Elite Model	-40°C to +65°C -	-40°C to +65°C -55°C to +85°C	-40°C to +65°C -	-40°C to +65°C -
Special Features		Multi-throw	High Frequency Multi-throw	Multi-throw	Multi-throw
Typical Contact Life Switch with Indicator Contacts		3,000,000 cycles 1,000,000 cycles	5,000,000 cycles 1,000,000 cycles	3,000,000 cycles 1,000,000 cycles	3,000,000 cycles 1,000,000 cycles
Typical RF Performance	VSWR (max)	DC-6 GHz : 1.30:1 6-12 GHz : 1.40:1	DC-4 GHz : 1.05:1 4-8 GHz : 1.10:1 8-12 GHz : 1.20:1 12-16 GHz : 1.20:1 16-20 GHz : 1.20:1 20-22 GHz : 1.20:1	DC-3 GHz : 1.30:1 3-6 GHz : 1.30:1 6-12 GHz : 1.40:1 12-18 GHz : 1.60:1	DC-2 GHz : 1.15:1 2-4 GHz : 1.30:1 4-8 GHz : 1.35:1 8-12 GHz : 1.40:1 12-18 GHz : 1.60:1
	Insertion Loss (max)	DC-6 GHz : 0.20 dB 6-12 GHz : 0.40 dB	DC-4 GHz : 0.10 dB 4-8 GHz : 0.20 dB 8-12 GHz : 0.20 dB 12-16 GHz : 0.30 dB 16-20 GHz : 0.30 dB 20-22 GHz : 0.30 dB	DC-3 GHz : 0.20 dB 3-6 GHz : 0.20 dB 6-12 GHz : 0.40 dB 12-18 GHz : 0.50 dB	DC-2 GHz : 0.15 dB 2-4 GHz : 0.30 dB 4-8 GHz : 0.40 dB 8-12 GHz : 0.50 dB 12-18 GHz : 0.70 dB
	Isolation (min)	DC-6 GHz : 70 dB 6-12 GHz : 60 dB	DC-4 GHz : 80 dB 4-8 GHz : 80 dB 8-12 GHz : 80 dB 12-16 GHz : 80 dB 16-20 GHz : 75 dB 20-22 GHz : 75 dB	DC-3 GHz : 70 dB 3-6 GHz : 70 dB 6-12 GHz : 60 dB 12-18 GHz : 60 dB	DC-2 GHz : 80 dB 2-4 GHz : 75 dB 4-8 GHz : 70 dB 8-12 GHz : 65 dB 12-18 GHz : 60 dB
Options	Self Cutoff (Latching Only)	✓	✓	—	—
	Indicator Contacts	✓	✓	✓	✓
	Self Cutoff and Indicator Con- tacts (Latching Only)	✓	✓	—	—
	TTL Interface	✓	✓	✓	✓
	TTL Decoder	✓	✓	✓	✓
	Moisture Seal	✓	✓	✓	✓
	Narrow Body	—	—	—	—
	Coil Transient Suppression Diodes and Polarity Protection Diode	✓	✓	✓	✓
Sub-D Connector	✓	✓	✓	✓	
Typical Mechanical Outline		3.10 x 2.77 x 3.10 in. 78.7 x 70.4 x 78.7 mm See Page 39	2.25 x 2.50 x 2.25 in. 57.2 x 63.5 x 57.2 mm See Page 36	2.50 x 2.87 x 2.50 in. 63.5 x 72.9 x 63.5 mm	2.50 x 2.87 x 2.50 in. 63.5 x 72.9 x 63.5 mm



RoHS or Non-RoHS:
Your Choice!



Series (Commercial/Elite)		CCT-39/CT-39	CCT-39	CCT-39	CCT-59/CT-59
Configuration		SP3T to SP6T	SP7T to SP8T	SP9T to SP10T	SP3T to SP6T
Switch Function		Latching	Latching	Latching	Latching
Frequency	Commercial Model Elite Model	DC to 18 GHz DC to 22 GHz	DC to 12 GHz -	DC to 12 GHz -	DC to 26.5 GHz DC to 26.5 GHz
Coil Voltages Available		12, 15, 24, 28	12, 15, 24, 28	12, 15, 24, 28	12, 15, 24, 28
Connectors Available		SMA	SMA	SMA	SMA
Temperature Range	Commercial Model Elite Model	-40°C to +65°C -55°C to +85°C	-40°C to +65°C -	-40°C to +65°C -	-40°C to +65°C -55°C to +85°C
Special Features		50-Ohm Internal Termination	50-Ohm Internal Termination	50-Ohm Internal Termination	High Frequency Terminated
Typical Contact Life Switch with Indicator Contacts		5,000,000 cycles 1,000,000 cycles	3,000,000 cycles 1,000,000 cycles	3,000,000 cycles 1,000,000 cycles	5,000,000 cycles 1,000,000 cycles
Typical RF Performance	VSWR (max)	DC-4 GHz : 1.05:1 4-8 GHz : 1.10:1 8-12 GHz : 1.20:1 12-16 GHz : 1.20:1 16-20 GHz : 1.20:1 20-22 GHz : 1.20:1	DC-6 GHz : 1.30:1 6-12 GHz : 1.40:1	DC-4 GHz : 1.10:1 4-8 GHz : 1.25:1 8-10 GHz : 1.30:1	DC-4 GHz : 1.05:1 4-8 GHz : 1.10:1 8-12 GHz : 1.20:1 12-16 GHz : 1.20:1 16-20 GHz : 1.20:1 20-22 GHz : 1.20:1
	Insertion Loss (max)	DC-4 GHz : 0.10 dB 4-8 GHz : 0.20 dB 8-12 GHz : 0.20 dB 12-16 GHz : 0.30 dB 16-20 GHz : 0.30 dB 20-22 GHz : 0.30 dB	DC-6 GHz : 0.20 dB 6-12 GHz : 0.40 dB	DC-4 GHz : 0.10 dB 4-8 GHz : 0.20 dB 8-10 GHz : 0.30 dB	DC-4 GHz : 0.10 dB 4-8 GHz : 0.20 dB 8-12 GHz : 0.20 dB 12-16 GHz : 0.30 dB 16-20 GHz : 0.30 dB 20-22 GHz : 0.30 dB
	Isolation (min)	DC-4 GHz : 80 dB 4-8 GHz : 80 dB 8-12 GHz : 80 dB 12-16 GHz : 80 dB 16-20 GHz : 75 dB 20-22 GHz : 75 dB	DC-6 GHz : 70 dB 6-12 GHz : 60 dB	DC-4 GHz : 80 dB 4-8 GHz : 80 dB 8-10 GHz : 80 dB	DC-4 GHz : 80 dB 4-8 GHz : 80 dB 8-12 GHz : 80 dB 12-16 GHz : 80 dB 16-20 GHz : 75 dB 20-22 GHz : 75 dB
Options	Self Cutoff (Latching Only)	✓	✓	✓	✓
	Indicator Contacts	✓	✓	✓	✓
	Self Cutoff and Indicator Contacts (Latching Only)	✓	✓	✓	✓
	TTL Interface	✓	✓	✓	✓
	TTL Decoder	✓	✓	✓	✓
	Moisture Seal	✓	✓	✓	✓
	Narrow Body	—	—	—	—
	Coil Transient Suppression Diodes and Polarity Protection Diode	✓	✓	✓	✓
Sub-D Connector	✓	✓	✓	✓	
Typical Mechanical Outline		2.25 x 2.50 x 2.25 in. 57.2 x 63.5 x 57.2 mm See Page 36	2.50 x 2.87 x 2.50 in. 63.5 x 72.9 x 63.5 mm See Page 39	3.10 x 2.77 x 3.10 in. 78.7 x 70.4 x 78.7 mm See Page 39	2.25 x 2.50 x 2.25 in. 57.2 x 63.5 x 57.2 mm See Page 36



Series (Commercial)		CCT-59	CCS-18/CS-18	CCS-19/CS-19	CCP-33S
Configuration		SP7T to SP8T	SP3T to SP8T	SP3T to SP6T	SPDT
Switch Function		Latching	Normally Open	Latching	Latching
Frequency	Commercial Model	DC to 18 GHz -	DC to 12 GHz DC to 12 GHz	DC to 2 GHz DC to 2 GHz	DC to 3 GHz -
Coil Voltages Available		12, 15, 24, 28	12, 15, 24, 28	12, 15, 24, 28	12, 15, 24, 28
Connectors Available		SMA	N, TNC	N, TNC	SMA
Temperature Range	Commercial Model	-40°C to +65°C -	-40°C to +65°C -55°C to +85°C	-40°C to +65°C -55°C to +85°C	-40°C to +65°C -
Special Features		50-Ohm Internal Termination	High RF Power Handling	High RF Power Handling	Low PIM
Typical Contact Life		3,000,000 cycles	3,000,000 cycles	3,000,000 cycles	1,000,000 cycles
Switch with Indicator Contacts		1,000,000 cycles	1,000,000 cycles	1,000,000 cycles	1,000,000 cycles
Passive Intermodulation Characteristics	VSWR (max)	DC-3 GHz : 1.30:1 3-6 GHz : 1.30:1 6-12 GHz : 1.40:1 12-18 GHz : 1.60:1	DC-3 GHz : 1.30:1 3-6 GHz : 1.30:1 6-9 GHz : 1.40:1 9-12 GHz : 1.70:1	DC-1 GHz : 1.15:1 1-2 GHz : 1.20:1	3rd Order Intermodulation: 1900 MHz -142.2 dBc Peak PIM
	Insertion Loss (max)	DC-3 GHz : 0.20 dB 3-6 GHz : 0.20 dB 6-12 GHz : 0.40 dB 12-18 GHz : 0.50 dB	DC-3 GHz : 0.20 dB 3-6 GHz : 0.20 dB 6-9 GHz : 0.30 dB 9-12 GHz : 0.40 dB	DC-1 GHz : 0.7 dB 1-2 GHz : 0.9 dB	Tone 1 Frequency: 1945 MHz @ 43 dBm
	Isolation (min)	DC-3 GHz : 70 dB 3-6 GHz : 70 dB 6-12 GHz : 60 dB 12-18 GHz : 60 dB	DC-3 GHz : 80 dB 3-6 GHz : 80 dB 6-9 GHz : 80 dB 9-12 GHz : 70 dB	DC-1 GHz : 80 dB 1-2 GHz : 80 dB	Tone 2 Frequency: 1990 MHz @ 43 dBm
Options	Self Cutoff (Latching Only)	✓	—	—	✓
	Indicator Contacts	✓	✓	✓	✓
	Self Cutoff and Indicator Contacts (Latching Only)	✓	—	✓	✓
	TTL Interface	✓	✓	✓	✓
	TTL Decoder	✓	✓	✓	—
	Moisture Seal	✓	✓	✓	✓
	Narrow Body	—	—	—	✓
	Coil Transient Suppression Diodes and Polarity Protection Diode	✓	✓	✓	✓
Sub-D Connector	✓	✓	✓	✓	
Typical Mechanical Outline		2.50 x 2.87 x 2.50 in. 63.5 x 72.9 x 63.5 mm	3.08 x 2.65 x 3.25 in. 78.2 x 67.3 x 82.5 mm See Page 40	2.50 x 3.54 x 2.50 in. 63.5 x 89.9 x 63.5 mm See Page 42	1.34 x 1.97 x 0.52 in. 34.0 x 50.0 x 13.2 mm See Page 44



RoHS or Non-RoHS:
Your Choice!



Series (Commercial)		CCP-33S	CCP-33D	CCP-37S	CCP-47N
Configuration		SPDT	SPDT	Transfer Switch	Transfer Switch
Switch Function		Latching	Latching	Latching	Latching
Frequency	Commercial Model	DC to 3 GHz -	DC to 3 GHz -	DC to 3 GHz	DC to 3 GHz
Coil Voltages Available		12, 15, 24, 28	12, 15, 24, 28	12, 15, 24, 28	12, 15, 24, 28
Connectors Available		SMA	7/16 DIN	SMA	N
Temperature Range	Commercial Model	-40°C to +65°C -	-40°C to +65°C -	-40°C to +65°C	-25°C to +65°C
Special Features		Low PIM	Low PIM	Low PIM	Low PIM
Typical Contact Life		1,000,000 cycles	1,000,000 cycles	1,000,000 cycles	1,000,000 cycles
Switch with Indicator Contacts		1,000,000 cycles	1,000,000 cycles	1,000,000 cycles	1,000,000 cycles
Passive Intermodulation Characteristics	3rd Order Intermodulation	1900 MHz -142.2 dBc Peak PIM	1900 MHz -165.6 dBc Peak PIM	1900 MHz -146.7 dBc Peak PIM	1900 MHz -159.2 dBc Peak PIM
	Tone 1 Frequency	1945 MHz @ 43 dBm	1945 MHz @ 43 dBm	1945 MHz @ 43 dBm	1945 MHz @ 43 dBm
	Tone 2 Frequency	1990 MHz @ 43 dBm	1990 MHz @ 43 dBm	1990 MHz @ 43 dBm	1990 MHz @ 43 dBm
Options	Self Cutoff (Latching Only)	✓	✓	✓	✓
	Indicator Contacts	✓	✓	✓	✓
	Self Cutoff and Indicator Contacts (Latching Only)	✓	✓	✓	✓
	TTL Interface	✓	✓	✓	✓
	TTL Decoder	—	—	—	—
	Moisture Seal	✓	✓	✓	✓
	Narrow Body	✓	—	—	—
	Coil Transient Suppression Diodes and Polarity Protection Diode	✓	✓	✓	✓
Sub-D Connector	✓	✓	✓	✓	
Typical Mechanical Outline		1.34 x 1.97 x 0.52 in. 34.0 x 50.0 x 13.2 mm See Page 44	3.50 x 3.97 x 3.50 in. 88.9 x 100.8 x 88.9 mm See Page 46	2.16 x 2.27 x 1.32 in. 54.86 x 57.7 x 33.5 mm See Page 47	3.12 x 3.48 x 1.81 in. 79.24 x 88.4 x 45.9 mm See Page 48



Series (Commercial)		CCP-47D	CCP-18D	CCP-38S	CCP-18N
Configuration		Transfer Switch	SP3T to SP4T	SP3T to SP6T	SP3T to SP6T
Switch Function		Latching	Normally Open	Normally Open	Normally Open
Frequency	Commercial Model	DC to 3 GHz	DC to 3 GHz	DC to 3 GHz	DC to 3 GHz
Coil Voltages Available		12, 15, 24, 28	12, 15, 24, 28	12, 15, 24, 28	12, 15, 24, 28
Connectors Available		7/16 DIN	7/16 DIN	SMA	N
Temperature Range	Commercial Model	-25°C to +65°C	-40°C to +65°C	-40°C to +65°C	-40°C to +65°C
Special Feature		Low PIM	Low PIM	Low PIM	Low PIM
Typical Contact Life		1,000,000 cycles	1,000,000 cycles	1,000,000 cycles	1,000,000 cycles
Switch with Indicator Contacts		1,000,000 cycles	1,000,000 cycles	1,000,000 cycles	1,000,000 cycles
Passive Intermodulation Characteristics	3rd Order Intermodulation	1900 MHz -165.5 dBc Peak PIM	1900 MHz -156.6 dBc Peak PIM	1900 MHz -144.1 dBc Peak PIM	1900 MHz -146.7 dBc Peak PIM
	Tone 1 Frequency	1945 MHz @ 43 dBm	1945 MHz @ 43 dBm	1945 MHz @ 43 dBm	1945 MHz @ 43 dBm
	Tone 2 Frequency	1990 MHz @ 43 dBm	1990 MHz @ 43 dBm	1990 MHz @ 43 dBm	1990 MHz @ 43 dBm
Options	Self Cutoff (Latching Only)	✓	—	—	—
	Indicator Contacts	✓	✓	✓	✓
	Self Cutoff and Indicator Contacts (Latching Only)	✓	—	—	—
	TTL Interface	✓	✓	✓	✓
	TTL Decoder	—	✓	✓	✓
	Moisture Seal	✓	✓	✓	✓
	Narrow Body	—	—	—	—
	Coil Transient Suppression Diodes and Polarity Protection Diode	✓	✓	✓	✓
Sub-D Connector	✓	✓	✓	✓	
Typical Mechanical Outline		3.50 x 3.97 x 3.50 in. 88.9 x 100.8 x 88.9 mm See Page 49	4.01 x 4.27 x 4.01 in. 88.9 x 108.5 x 101.9 mm See Page 50	1.75 x 2.62 x 1.75 in. 88.9 x 66.5 x 44.5 mm See Page 51	2.50 x 3.14 x 2.50 in. 88.9 x 79.8 x 63.5 mm See Page 52



RoHS or Non-RoHS:
Your Choice!



Series

CAS-37

RF Contacts	3 State Attenuator Switch	Special Feature	3-States: Thru Path Attenuated Path, 20 dB 50 Ohm Internal Termination
Typical Contact Life	1,000,000 cycles		
Frequency	DC to 25 GHz	Weight	4 oz. (113.4 g) (max)
Coil Voltage	12, 15, 24, 28	Typical Mechanical Outline	1.27 x 2.25 x 1.37 in. 38.1 x 46.2 x 13.2 mm See Page 8
Connector	SMA	Shock	MIL-STD-202 Method 213, Condition D (500G Non Operating)
Temperature Range	0°C to +55°C	Vibration	MIL-STD-202 Method 214, Condition D (5G RMS Non Operating)
Typical RF Performance	VSWR, 20 dB Path (max)	VSWR, Thru Path (max)	DC-3 GHz : 1.11:1 3-9 GHz : 1.20:1 9-13 GHz : 1.25:1 13-18 GHz : 1.33:1 18-21 GHz : 1.33:1 21-25 GHz : 1.50:1
	Insertion Loss, Thru Path (max)	Isolation, Terminated State	DC-3 GHz : >60 dB 3-9 GHz : >60 dB 9-13 GHz : >60 dB 13-18 GHz : >60 dB 18-21 GHz : >60 dB 21-25 GHz : >60 dB
	Attenuation, 20 dB (dB max/min)	Frequency	Max. Min.
		DC-3 GHz:	+ .28 dB - .40 dB
		3-9 GHz:	+ .48 dB - .40 dB
		9-13 GHz:	+ .83 dB - .41 dB
		13-18 GHz:	+ 1.12 dB - .48 dB
		18-21 GHz:	+ 1.55 dB - .56 dB
		21-25 GHz:	+ 1.95 dB - .65 dB

See Page 51

Additional Unique Options

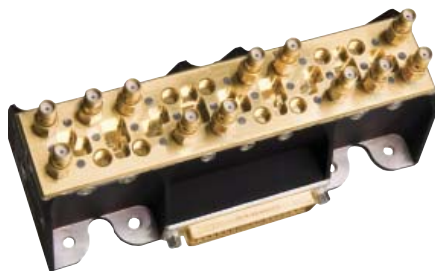

Switch Blocks



Alternative Connector Locations



Radiation Shielding Covers



6P7T Switch

Teledyne Coax Switches offers numerous options for coaxial switches:

- Double Insulation
- Radiation Shielding
- Customized Mounting Brackets
- Special Power Connectors
- Alternate RF Connectors
- Alternate DC terminal styles
- Short Covers
- PCB Mount RF Pins
- Switch Blocks
- 6P7T Switch Matrix
- Parallel or Series Diodes
- Redundant Diode Configuration
- Pressure Evacuation Vent



PCB Pin Option



Short Cover Option



DC Flying Leads



DC Long Flying Leads



QMA RF Connectors

Please feel free to contact us for more information regarding additional options and custom configurations.

Model Number

This guide shows the model numbers for switches by Teledyne Coax Switches. For technical support or custom switches for specific applications, call (800) 351-7368.

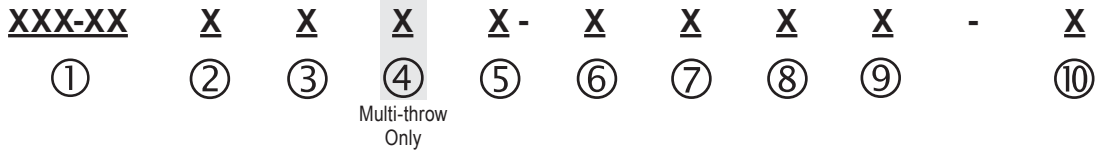

Example: CCR-33S10-T (Commercial SPDT, S=SMA, 28 Vdc, Failsafe, TTL)

All standard switches are RoHS compliant. Contact factory for other options.

①	Switch Model Series Type and Description									
	See tables on pages 2–7 for series name.									
②	Connector Type									
	<table style="width: 100%; border-collapse: collapse;"> <tr> <td style="width: 33%;">D 7/16 DIN Female</td> <td style="width: 33%;">N N Female</td> <td style="width: 33%;">HN High Power Type N Female</td> </tr> <tr> <td>K 2.92 mm Female</td> <td>S SMA Female</td> <td>HT High Power TNC Female</td> </tr> <tr> <td>M Mini SMB</td> <td>T TNC Female</td> <td></td> </tr> </table>	D 7/16 DIN Female	N N Female	HN High Power Type N Female	K 2.92 mm Female	S SMA Female	HT High Power TNC Female	M Mini SMB	T TNC Female	
D 7/16 DIN Female	N N Female	HN High Power Type N Female								
K 2.92 mm Female	S SMA Female	HT High Power TNC Female								
M Mini SMB	T TNC Female									
③	Actuator Voltage									
	<table style="width: 100%; border-collapse: collapse;"> <tr> <td style="width: 50%;">1 28 Vdc – Failsafe (Normally Open if single-pole multi-throw)</td> <td style="width: 50%;">6 28 Vdc – Latching*</td> </tr> <tr> <td>2 15 Vdc – Failsafe (Normally Open if single-pole multi-throw)</td> <td>7 15 Vdc – Latching*</td> </tr> <tr> <td>3 12 Vdc – Failsafe (Normally Open if single-pole multi-throw)</td> <td>8 12 Vdc – Latching*</td> </tr> <tr> <td>4 24 Vdc – Failsafe (Normally Open if single-pole multi-throw)</td> <td>9 24 Vdc – Latching*</td> </tr> </table>	1 28 Vdc – Failsafe (Normally Open if single-pole multi-throw)	6 28 Vdc – Latching*	2 15 Vdc – Failsafe (Normally Open if single-pole multi-throw)	7 15 Vdc – Latching*	3 12 Vdc – Failsafe (Normally Open if single-pole multi-throw)	8 12 Vdc – Latching*	4 24 Vdc – Failsafe (Normally Open if single-pole multi-throw)	9 24 Vdc – Latching*	
1 28 Vdc – Failsafe (Normally Open if single-pole multi-throw)	6 28 Vdc – Latching*									
2 15 Vdc – Failsafe (Normally Open if single-pole multi-throw)	7 15 Vdc – Latching*									
3 12 Vdc – Failsafe (Normally Open if single-pole multi-throw)	8 12 Vdc – Latching*									
4 24 Vdc – Failsafe (Normally Open if single-pole multi-throw)	9 24 Vdc – Latching*									
④	Number Positions for Multi-throw									
	3, 4, 5, 6, 7, 8, 9, 0=10 Indicates number of positions on multi-throw switches (skip this number if not single-pole multi-throw)									
⑤	Actuator Type									
	<table style="width: 100%; border-collapse: collapse;"> <tr> <td style="width: 50%;">0 No self-cutoff or indicator contacts</td> <td style="width: 50%;">D Self cutoff only</td> </tr> <tr> <td>C Indicator contacts only</td> <td>E Self cutoff and indicator contacts</td> </tr> </table>	0 No self-cutoff or indicator contacts	D Self cutoff only	C Indicator contacts only	E Self cutoff and indicator contacts					
0 No self-cutoff or indicator contacts	D Self cutoff only									
C Indicator contacts only	E Self cutoff and indicator contacts									
⑥	TTL Driver									
	<table style="width: 100%; border-collapse: collapse;"> <tr> <td style="width: 50%;">T TTL driver with diodes</td> <td style="width: 50%;">TD Decoders and TTL driver with diodes</td> </tr> </table>	T TTL driver with diodes	TD Decoders and TTL driver with diodes							
T TTL driver with diodes	TD Decoders and TTL driver with diodes									
⑦	Polarity									
	R Positive (+) Common. Option not available with T and TD options.									
⑧	Narrow Body and/or Moisture Seal									
	<table style="width: 100%; border-collapse: collapse;"> <tr> <td style="width: 50%;">N Narrow Body (SPDT switch only)</td> <td style="width: 50%;">M Moisture Seal</td> </tr> </table>	N Narrow Body (SPDT switch only)	M Moisture Seal							
N Narrow Body (SPDT switch only)	M Moisture Seal									
⑨	Coil Transient Suppression and/or Sub-D Connector									
	<table style="width: 100%; border-collapse: collapse;"> <tr> <td style="width: 50%;">D Coil Transient Suppression Diode & Polarity Protection Diode</td> <td style="width: 50%;">S Sub-D Connector</td> </tr> </table>	D Coil Transient Suppression Diode & Polarity Protection Diode	S Sub-D Connector							
D Coil Transient Suppression Diode & Polarity Protection Diode	S Sub-D Connector									
⑩	Custom Part Number									
	Assigned by Engineering									

*Polarity sensitive **Note: Normally Open terminated switches are polarity sensitive**

Space-qualified and custom switches available. Please contact factory for more information.

Teledyne Coax Switches Offers Unrivalled Insertion Loss Repeatability

RF relays are rated for ± 0.1 dB repeatability for 1M cycles. Teledyne coaxial switches offer better than ± 0.1 dB over certain frequencies.



CCR-33 Insertion Loss Repeatability, 50K cycles

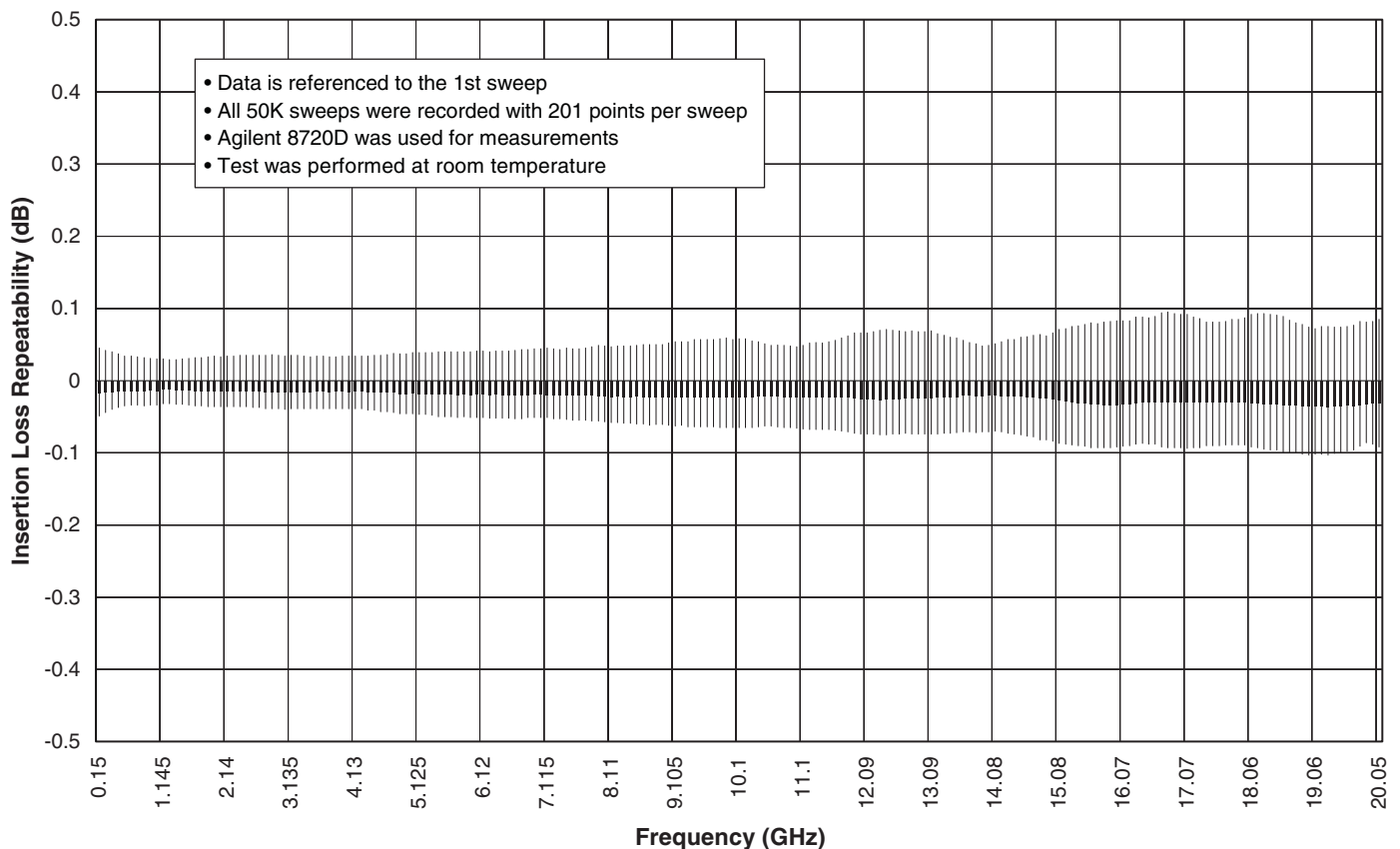

CCR-33/CR-33, CCR-53/CR-53, CCR-33K, CCR-40K

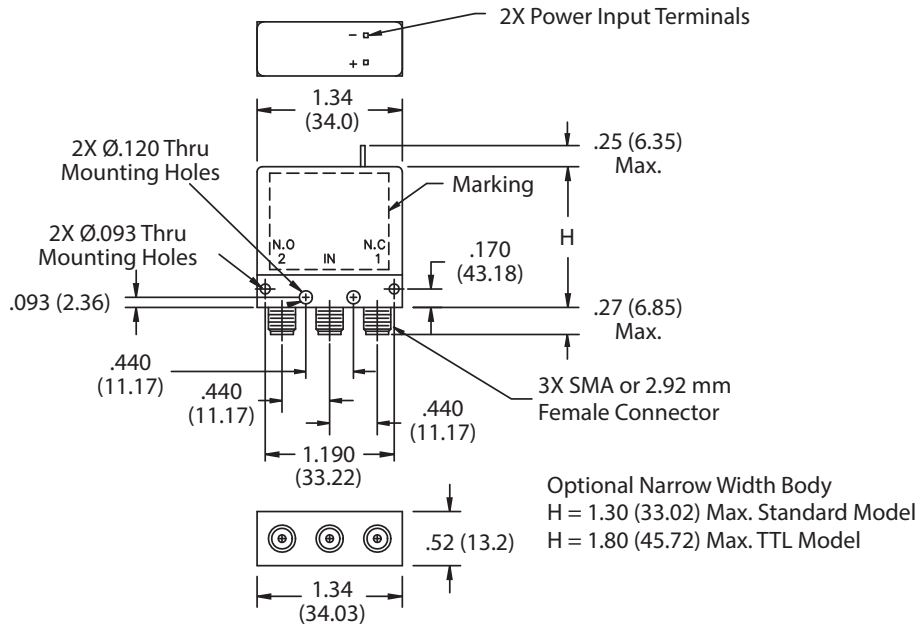
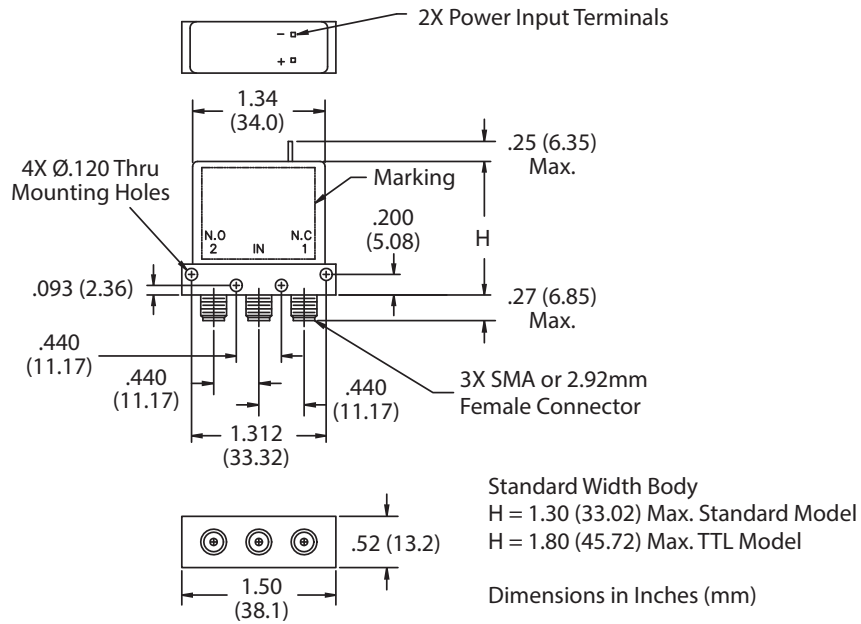

CCR-33/CR-33

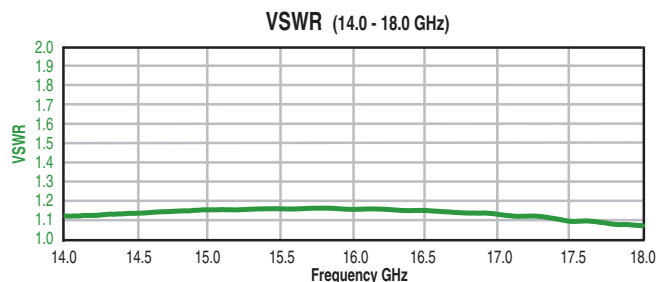
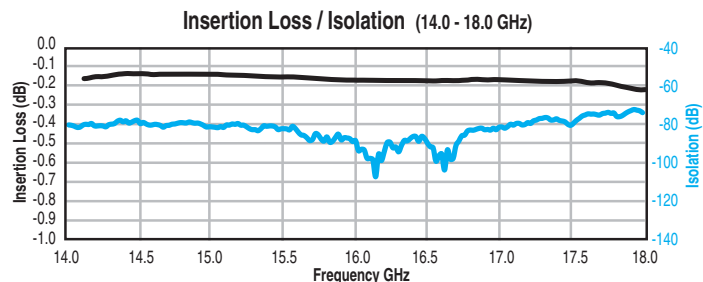
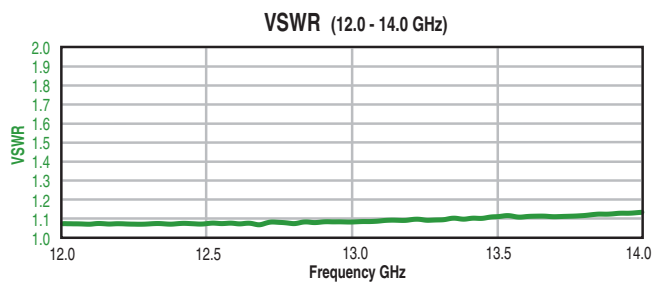
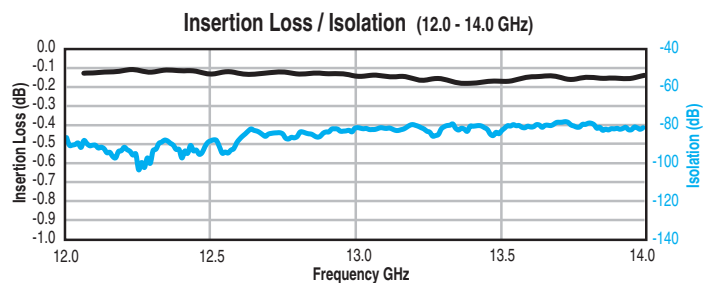
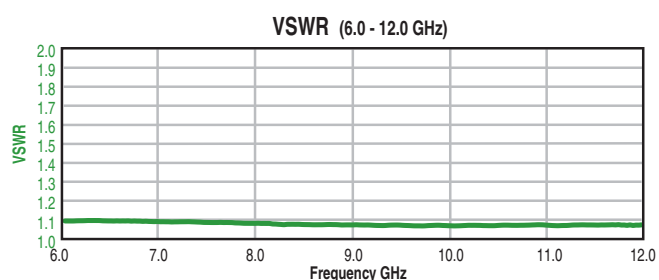
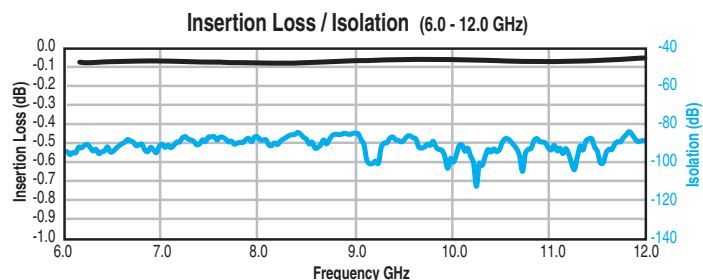
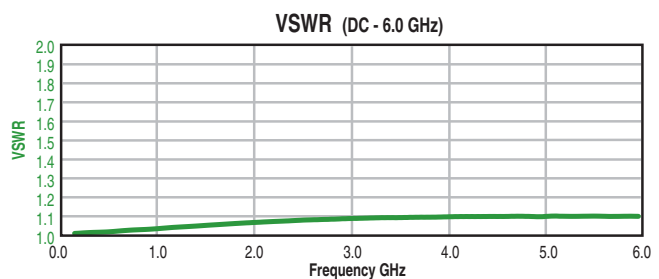
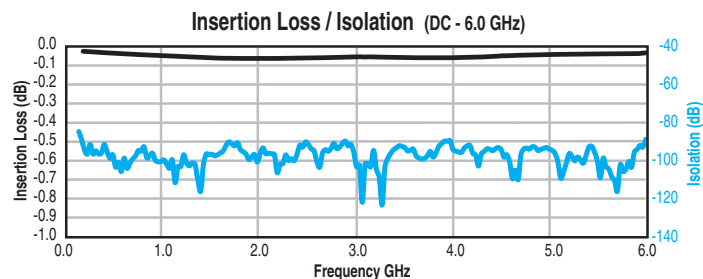

SPDT SWITCHES

CCR-53/CR-53

SPDT SWITCHES

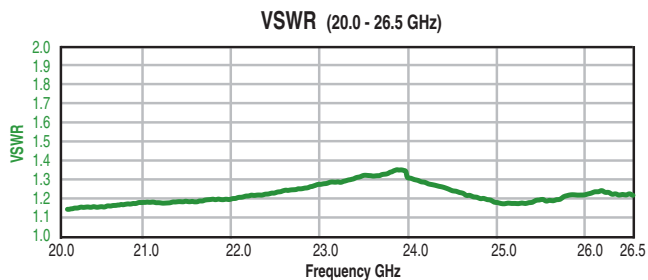
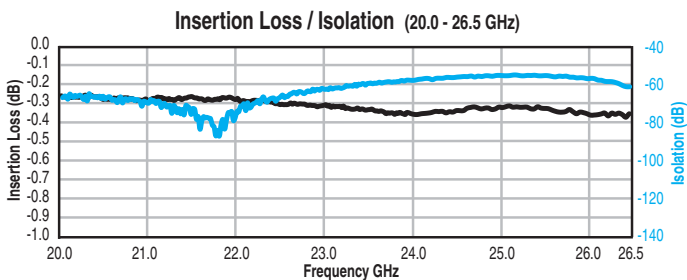
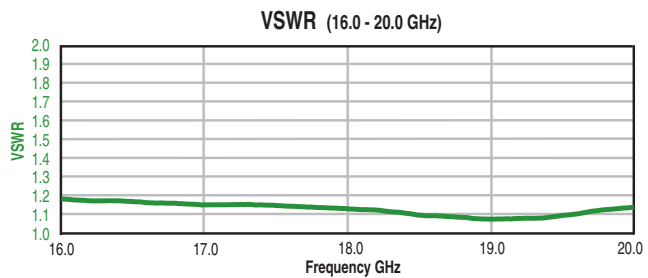
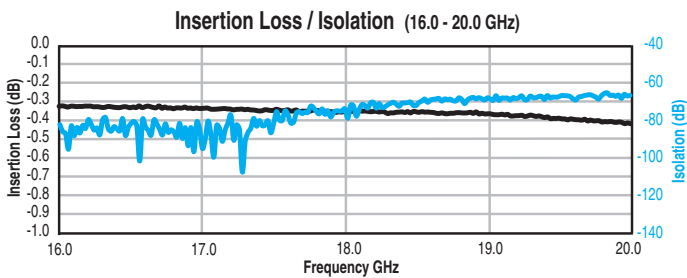
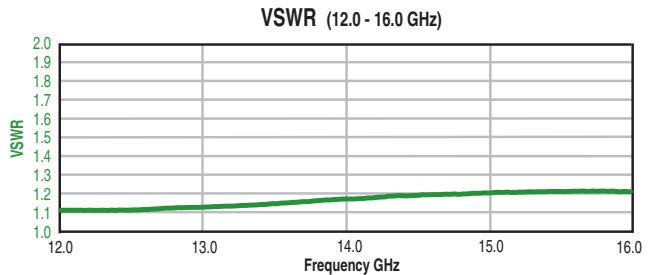
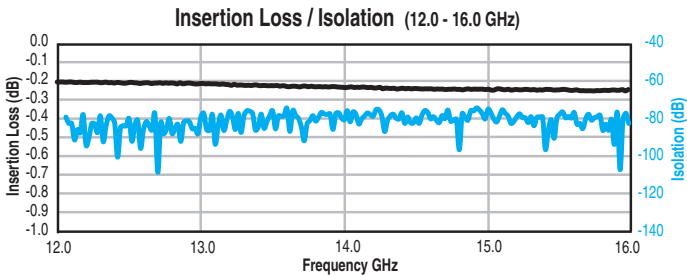
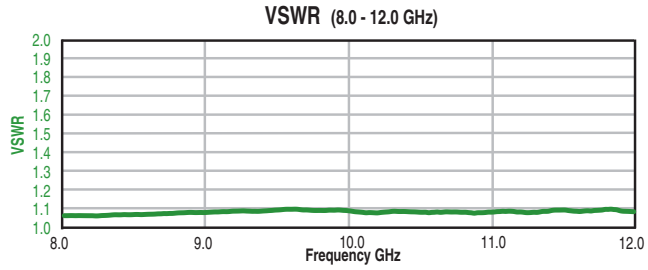
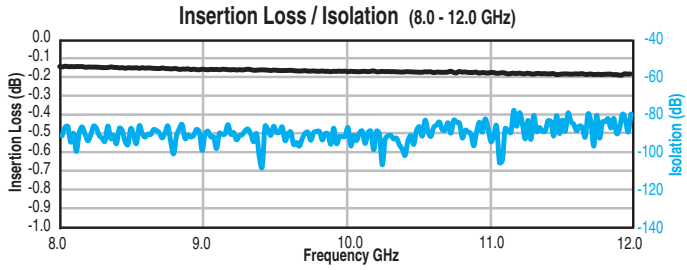
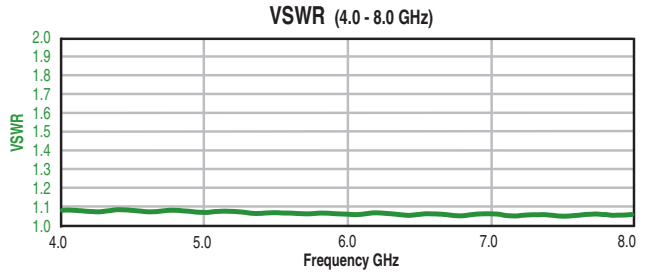
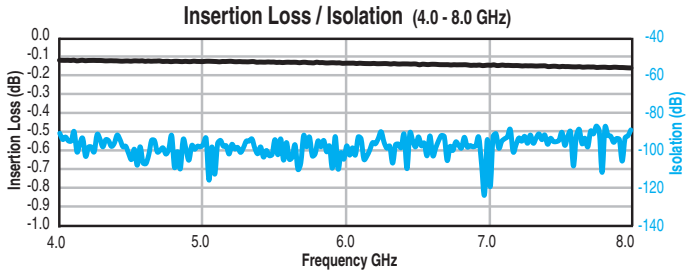
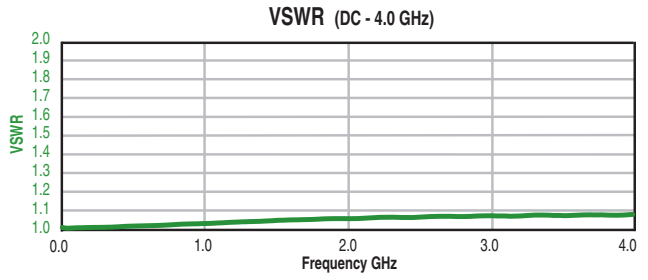
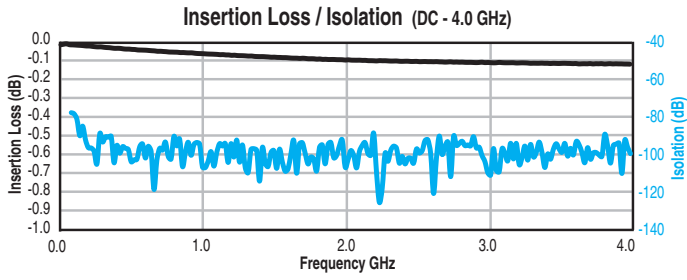

CCR-33K

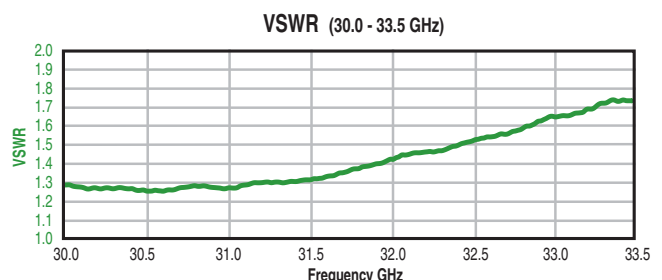
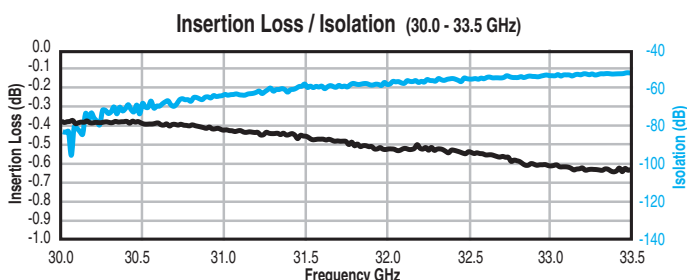
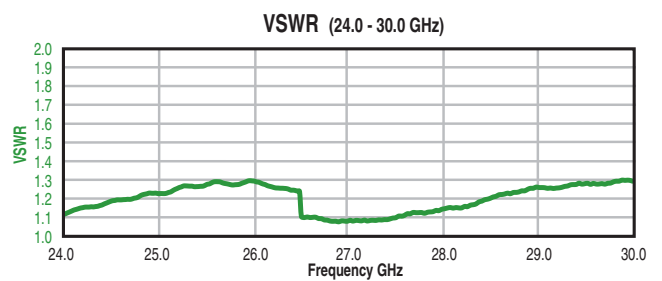
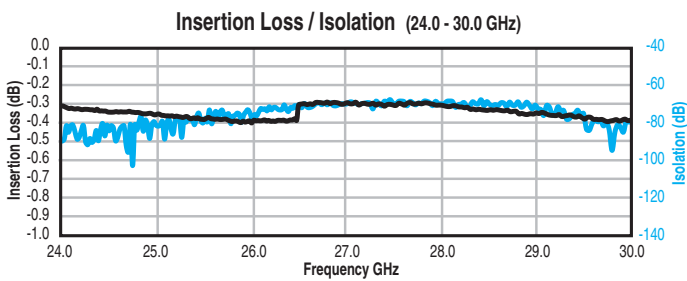
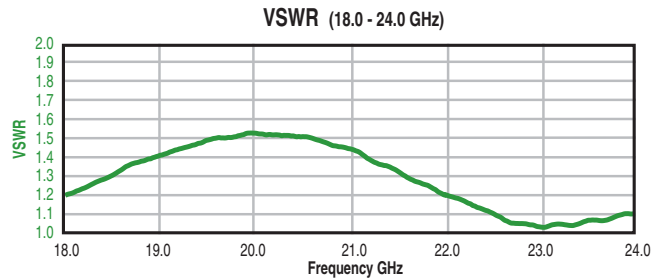
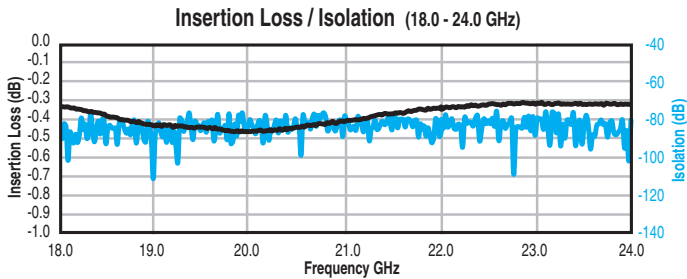
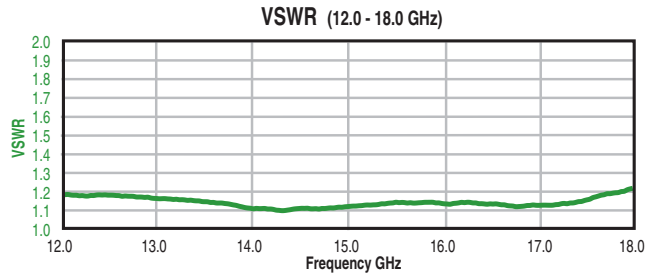
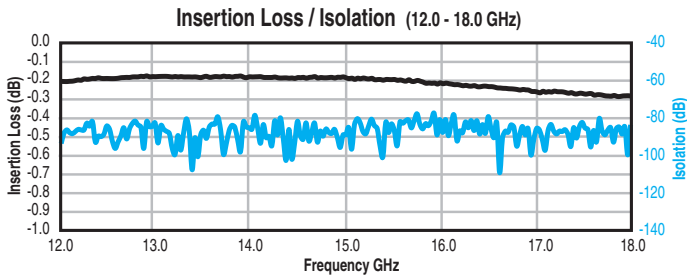
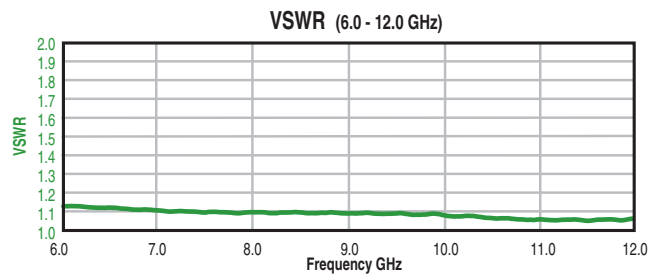
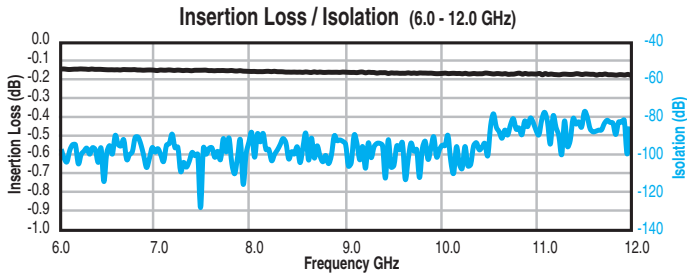
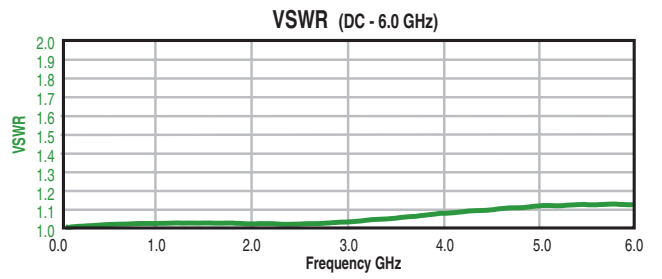
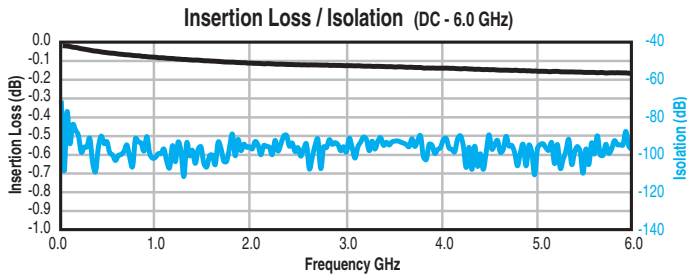

CCRT-33/CRT-33, CCRT-53/CRT-53

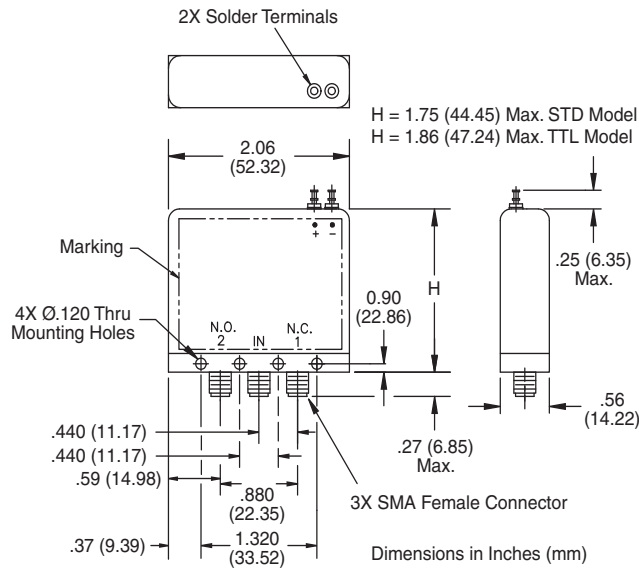

CCRT-33/CRT-33

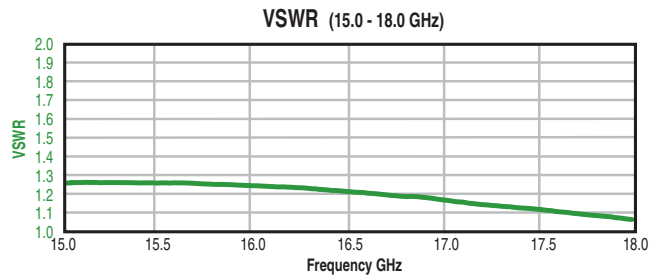
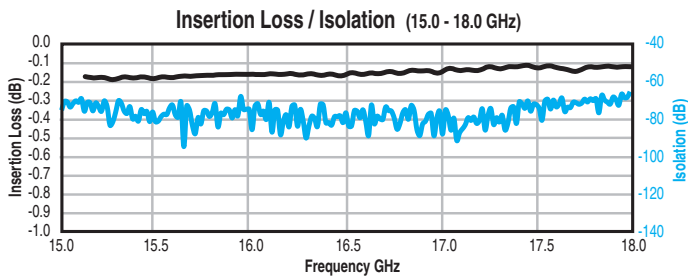
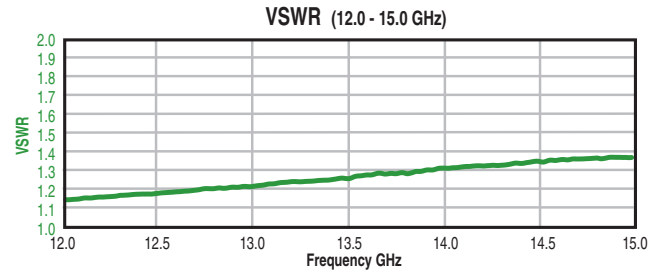
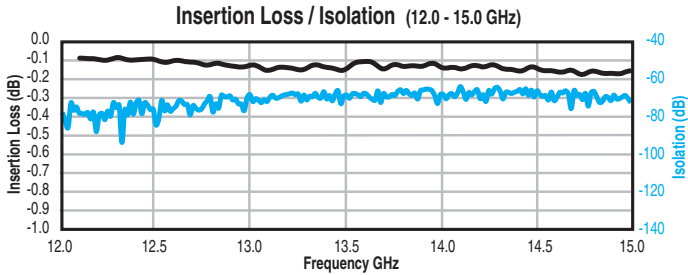
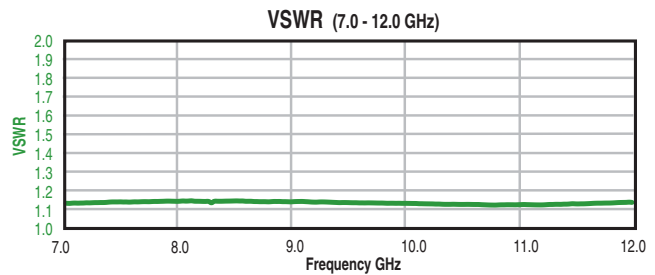
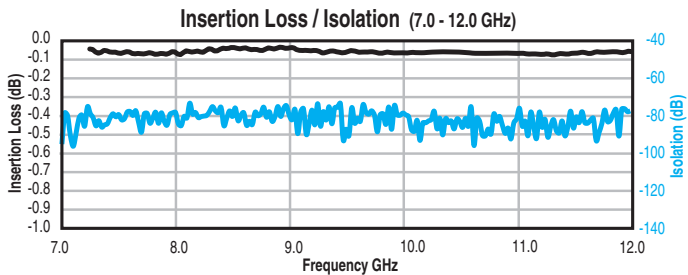
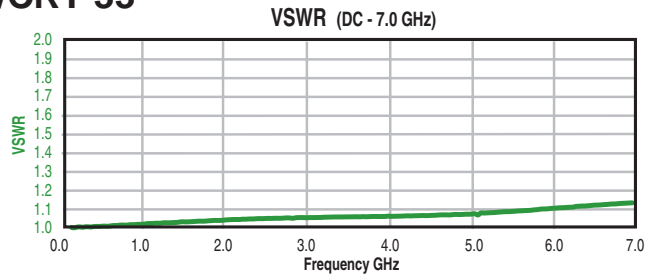
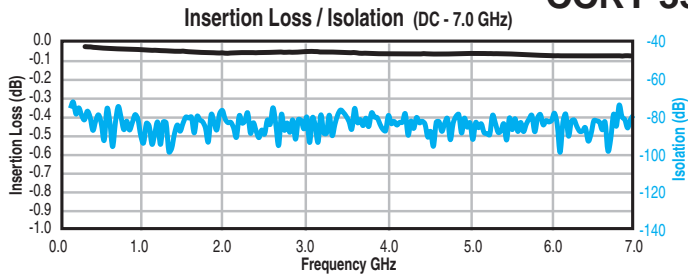

CCRT-53/CRT-53

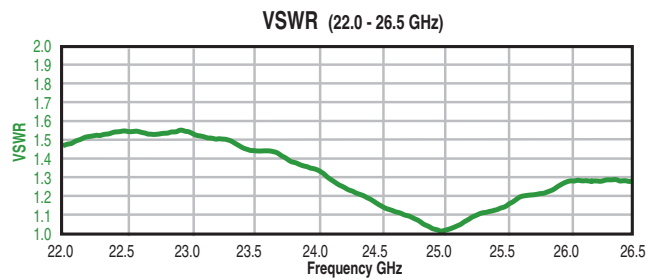
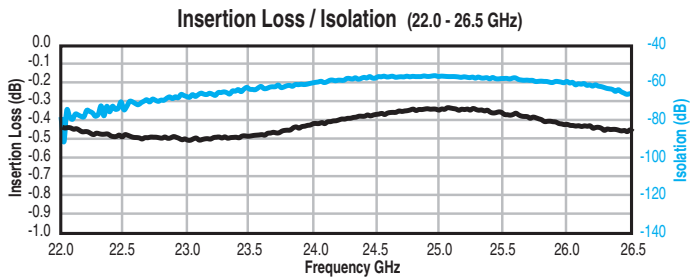
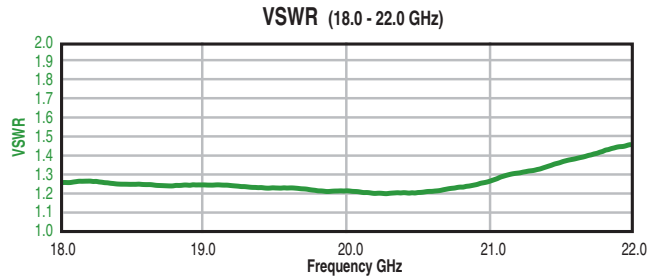
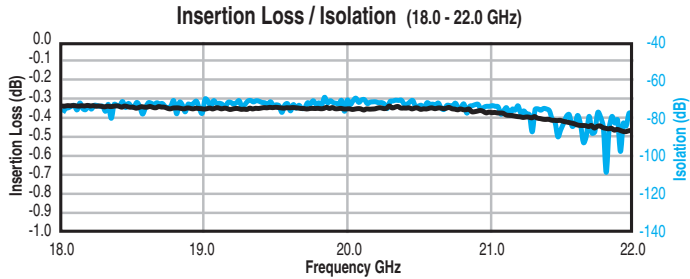
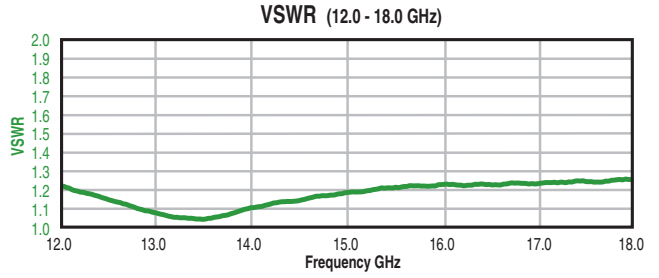
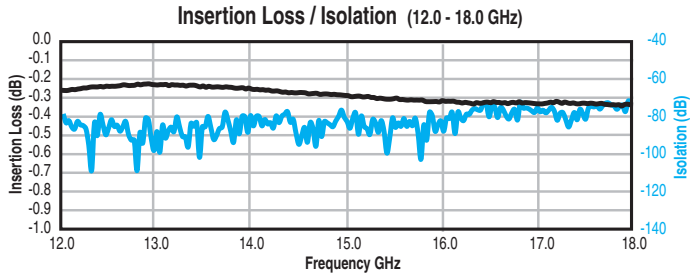
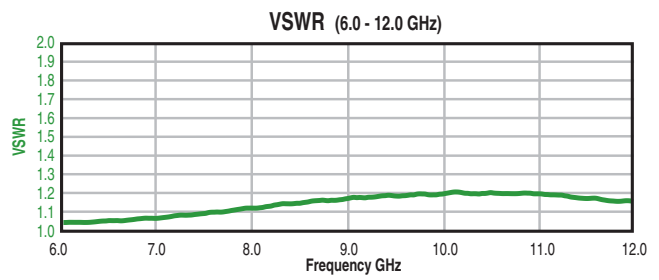
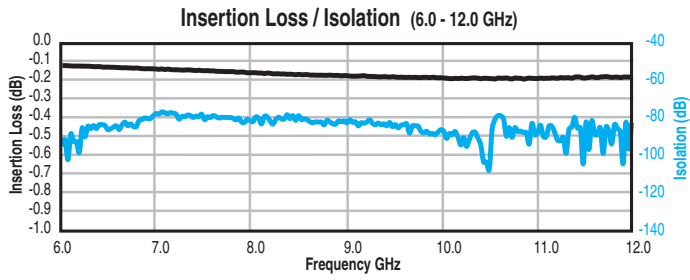
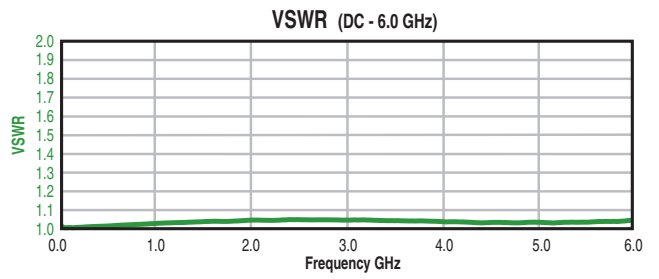
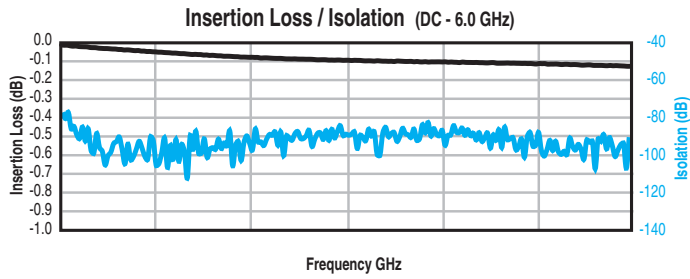

CCR-33M

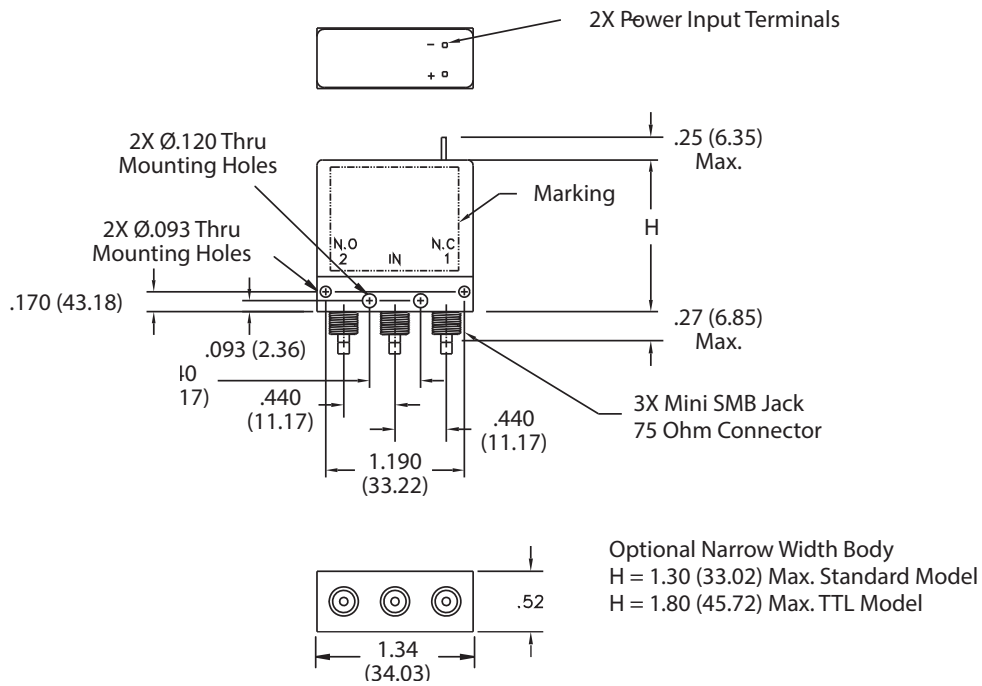
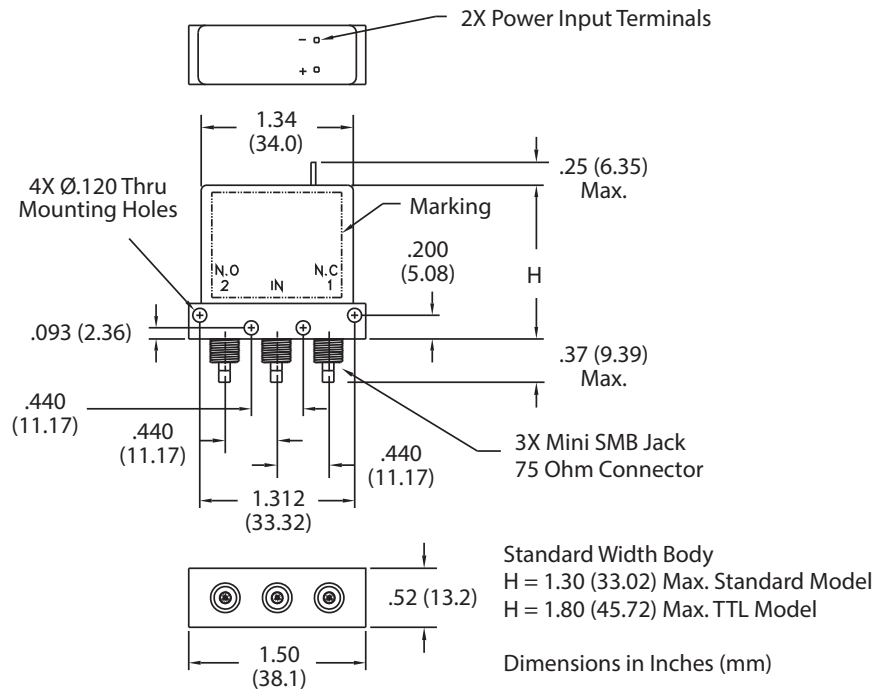

CCR-33M

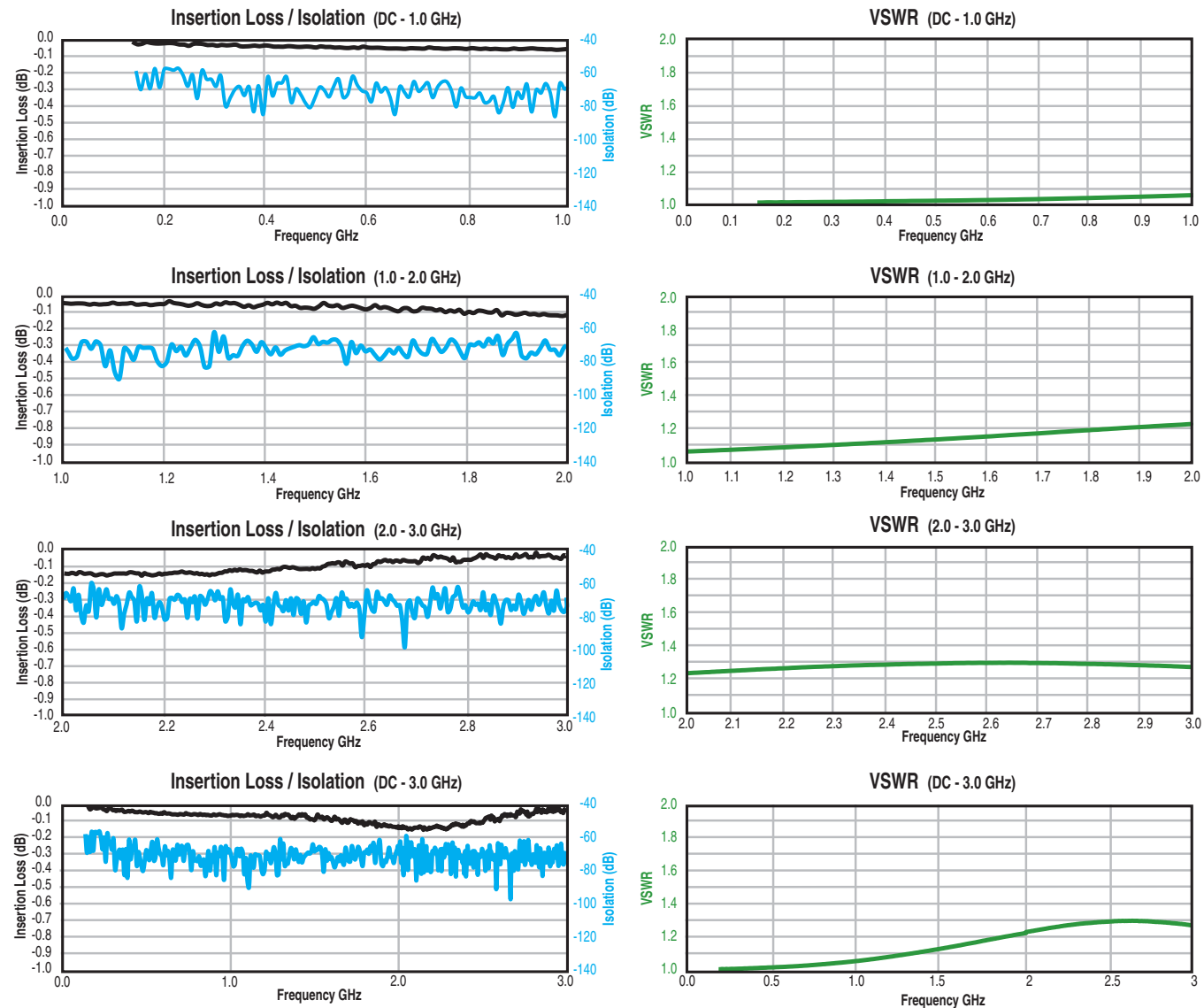

SPDT SWITCHES

CCS-32/CS-32

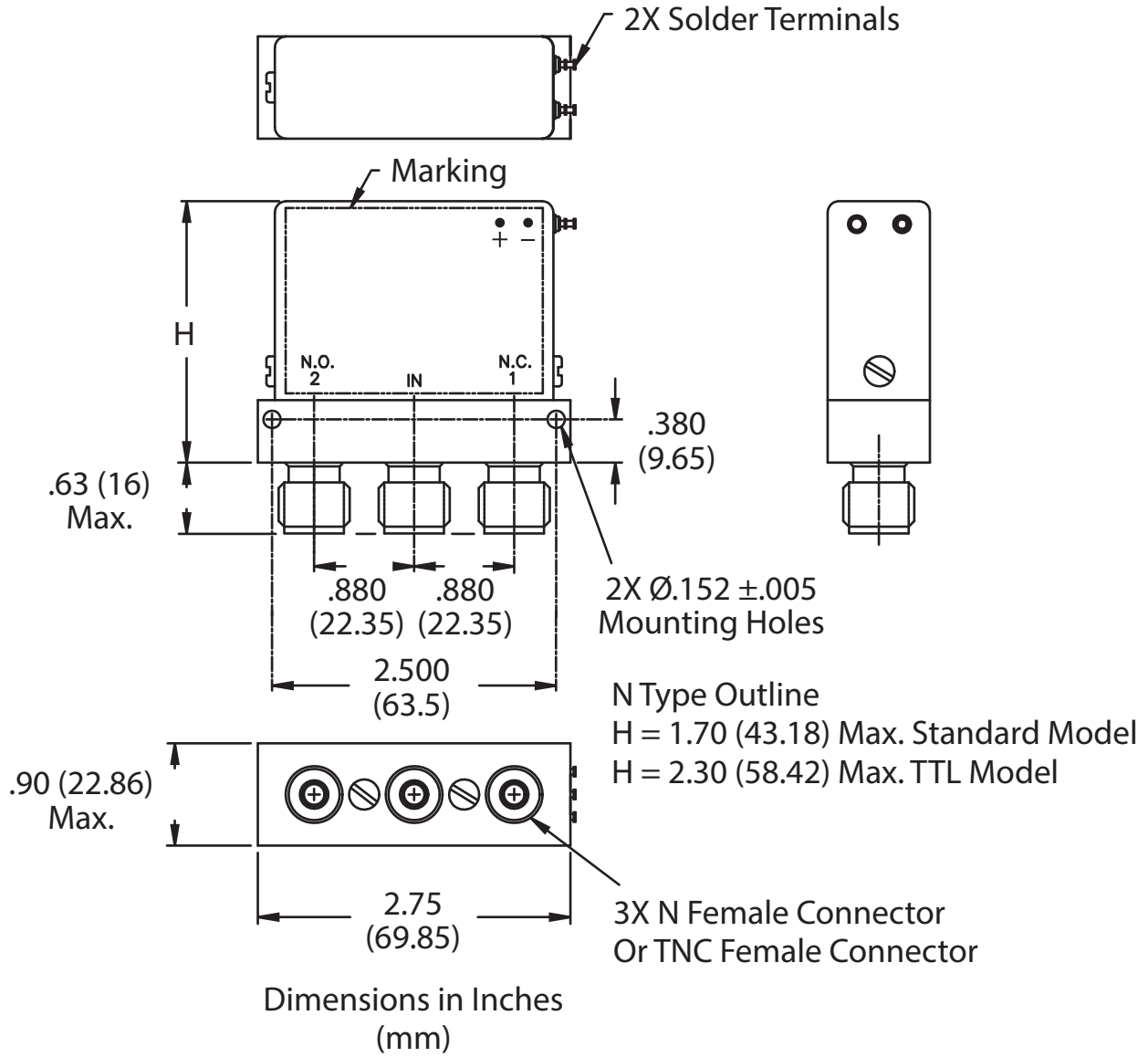

CCS-32/CS-32

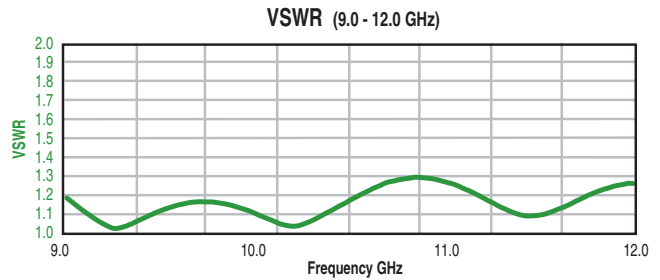
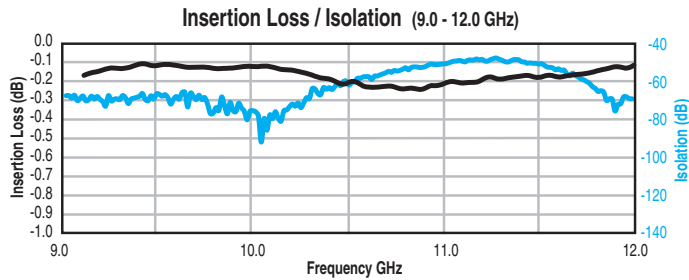
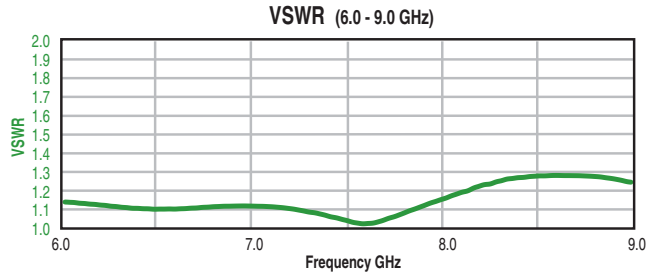
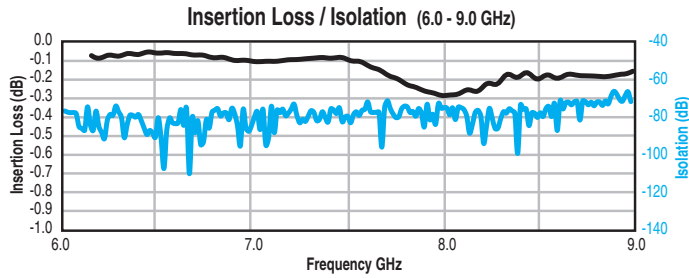
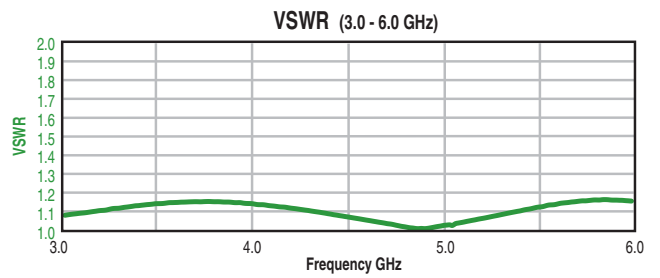
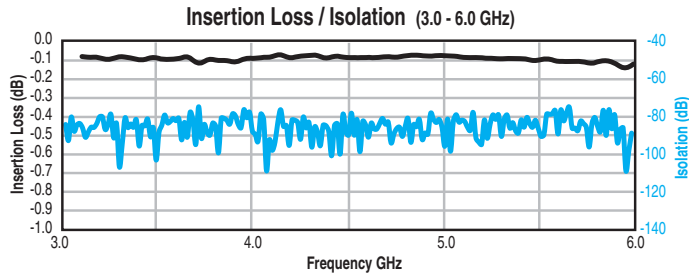
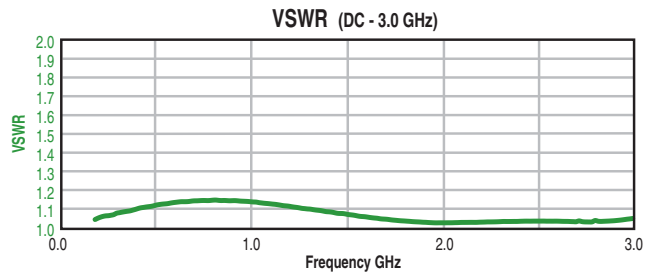
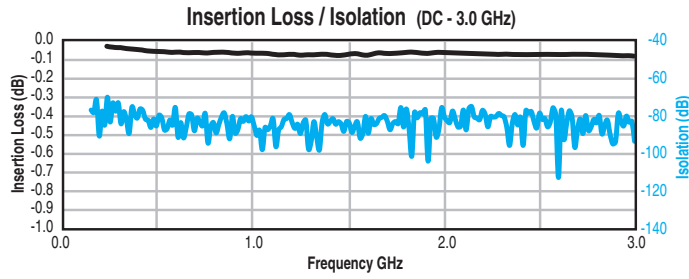

CCRS-33/CRS-33, CCRS-53/CRS-53

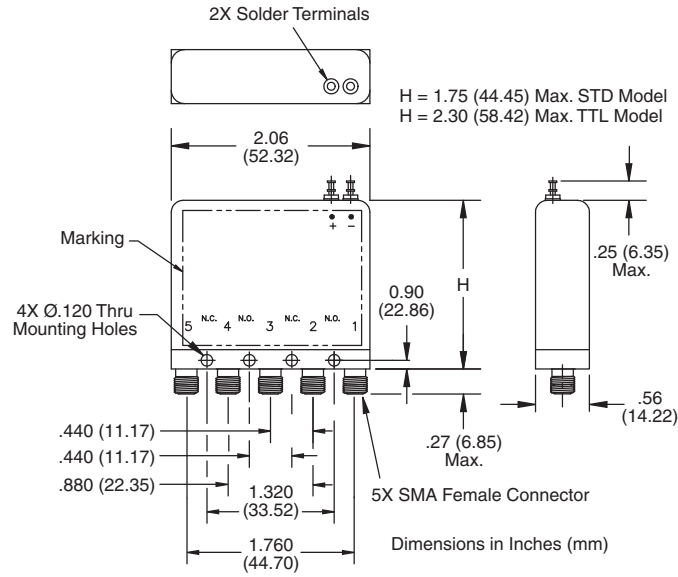

CCRS-33/CRS-33

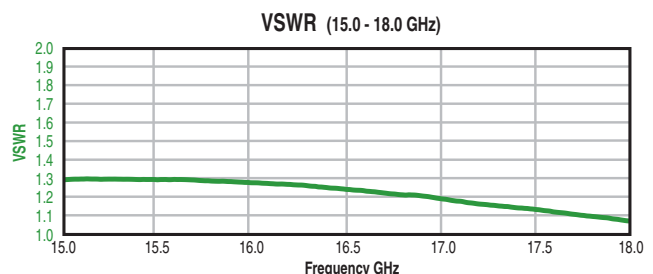
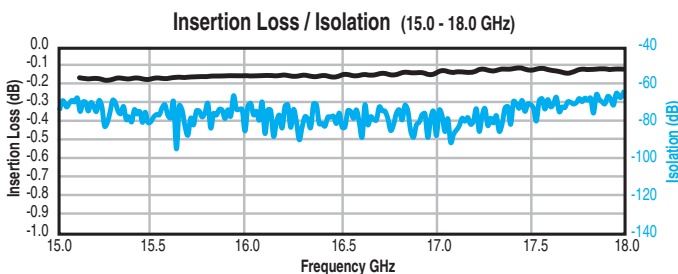
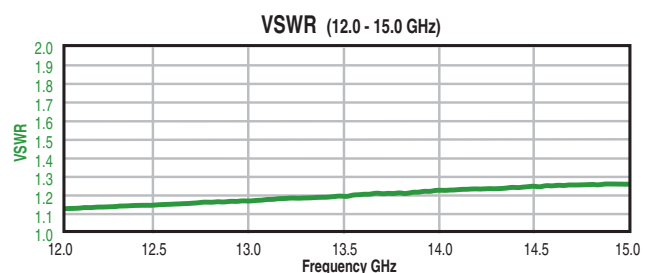
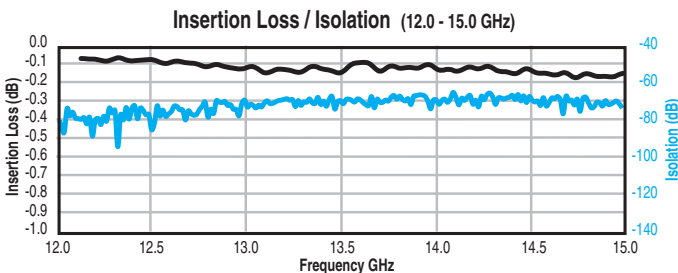
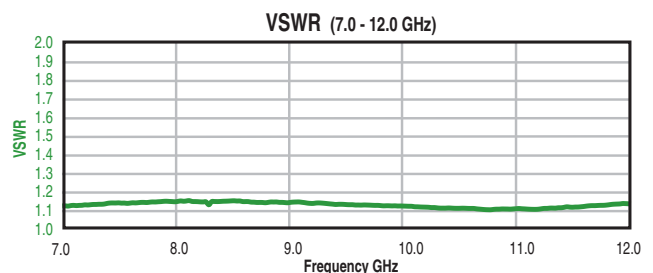
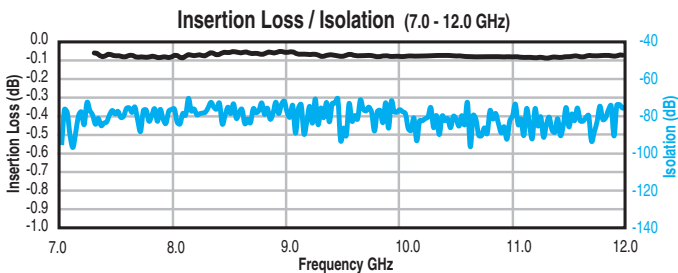
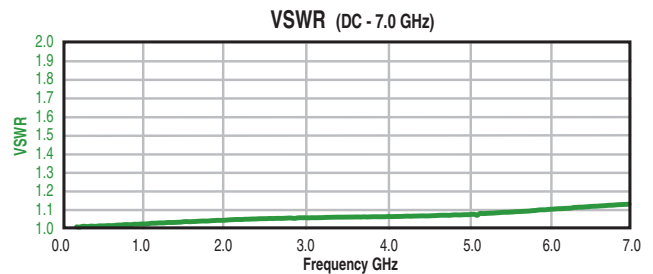
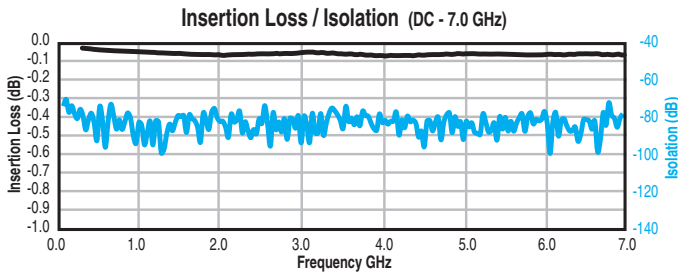

2P3T SWITCHES

CCRS-53/CRS-53

2P3T SWITCHES

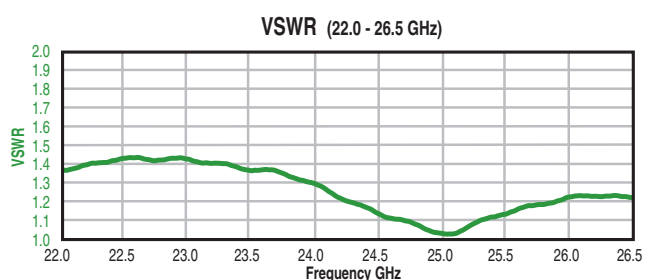
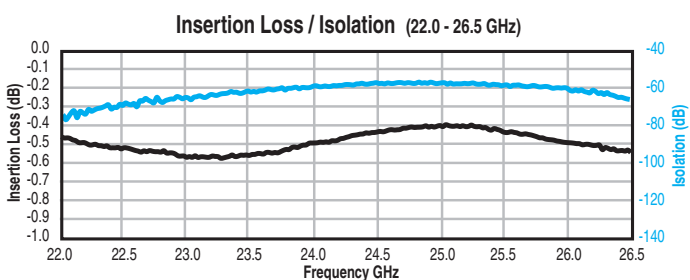
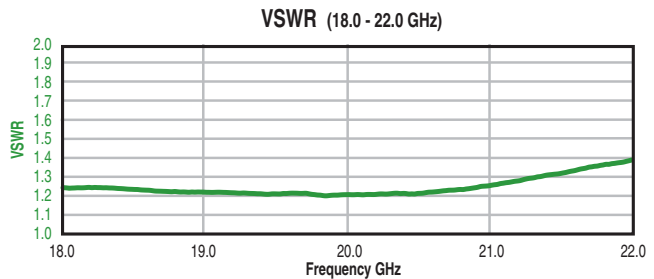
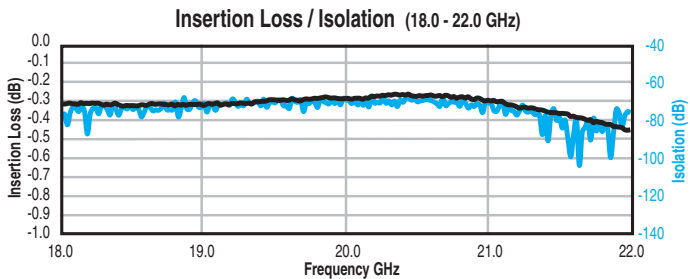
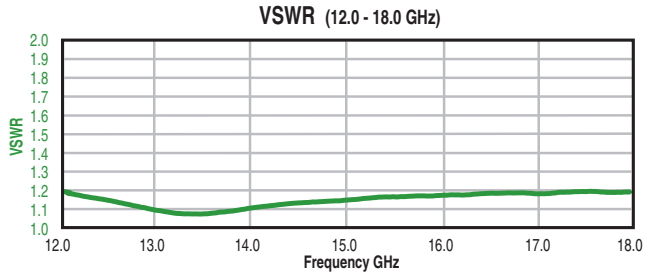
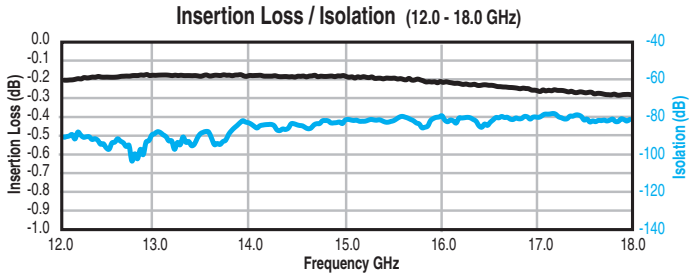
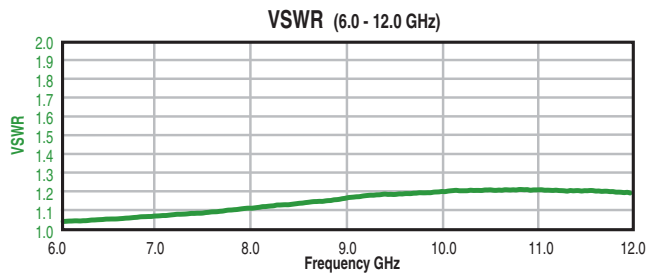
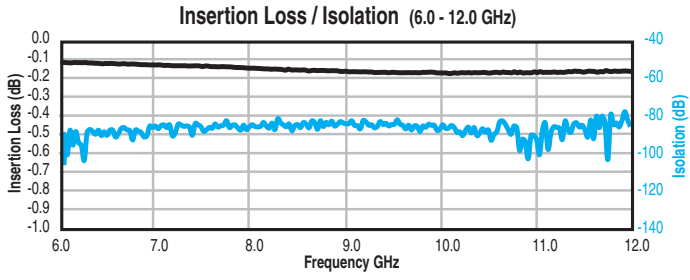
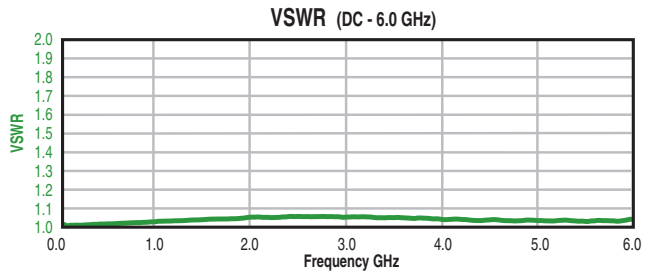
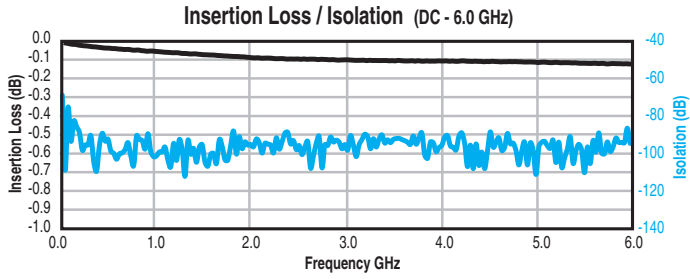

CCS-37/CS-37

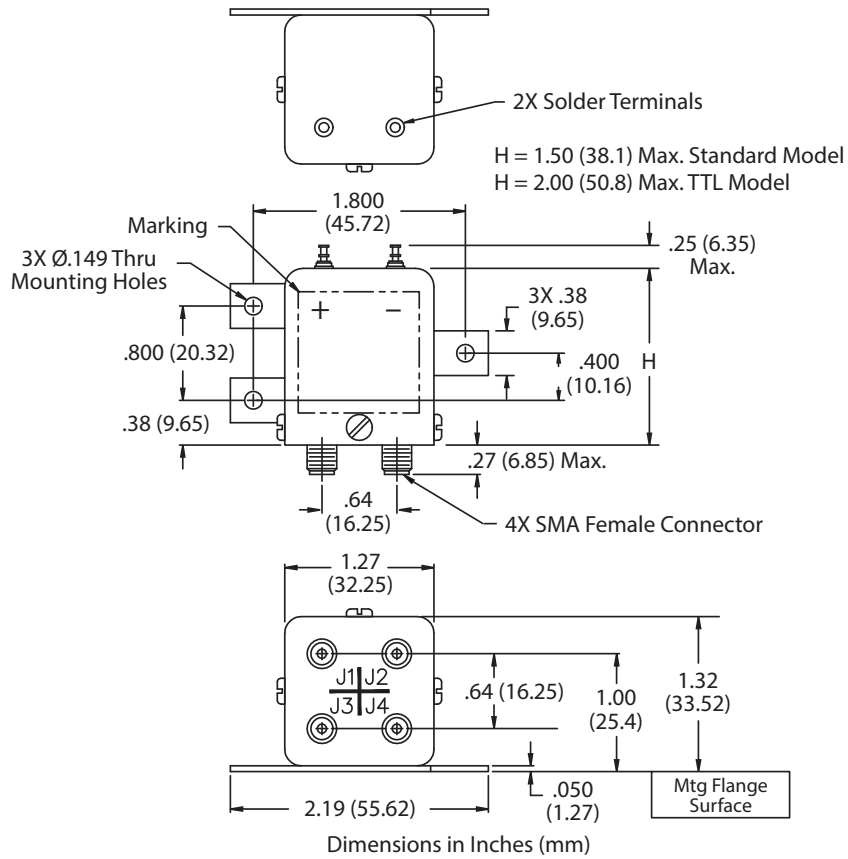

TRANSFER SWITCHES

CCS-37/CS-37

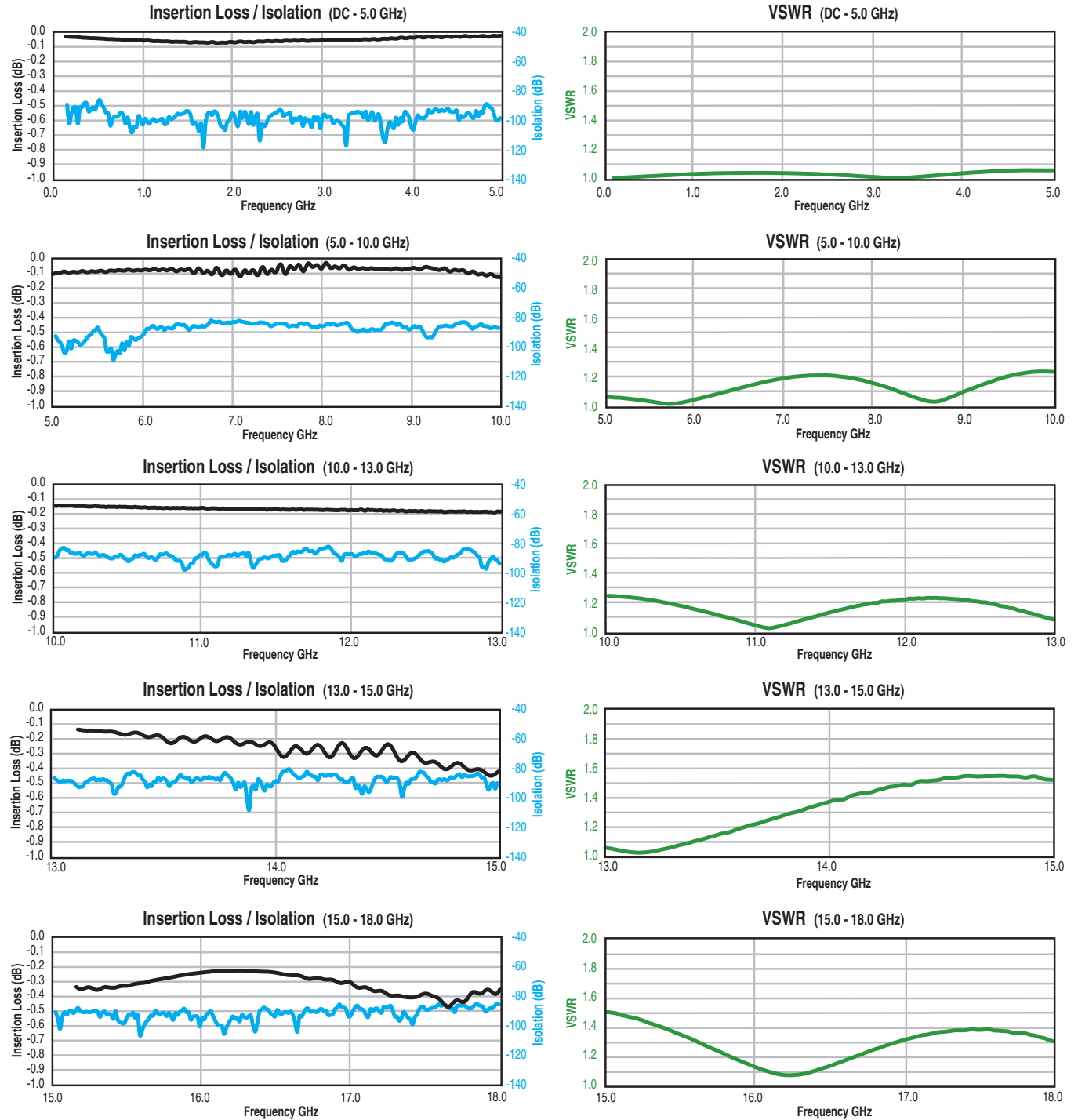

TRANSFER SWITCHES

CCS-47/CS-47

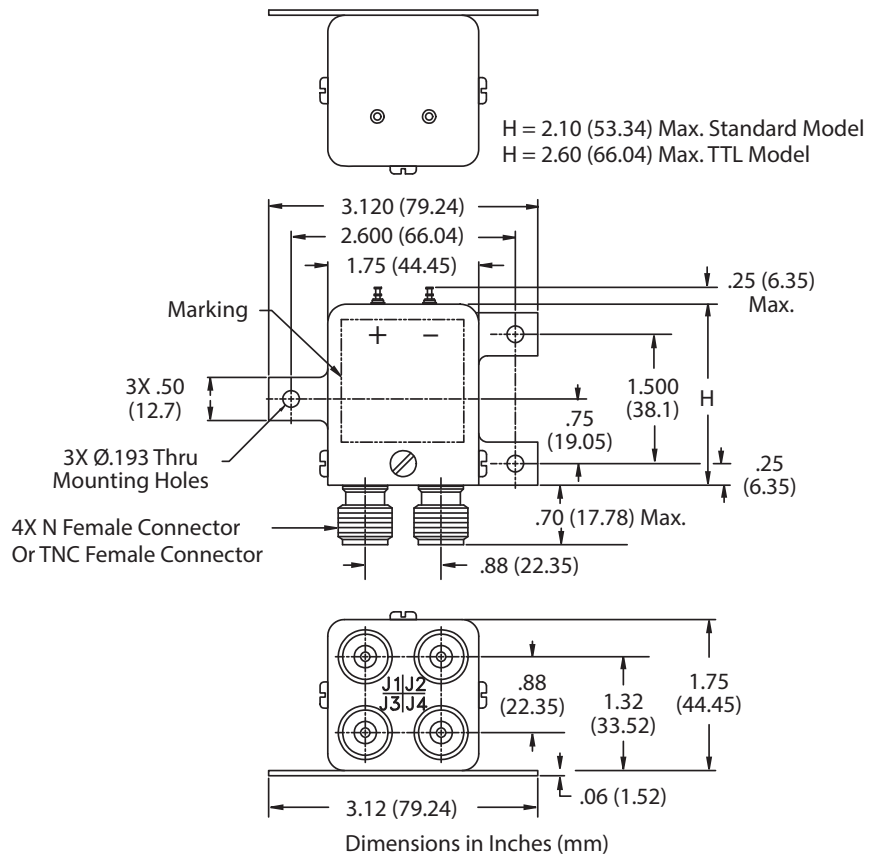

TRANSFER SWITCHES

CCS-47/CS-47

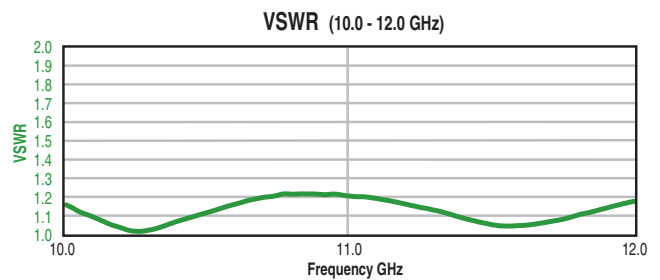
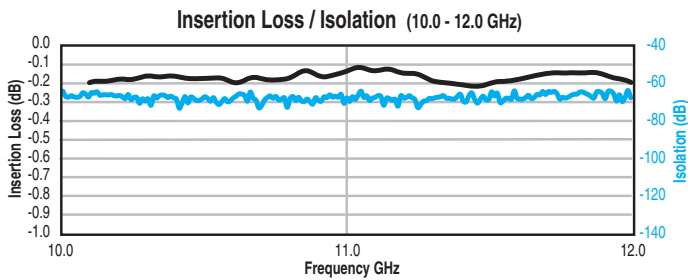
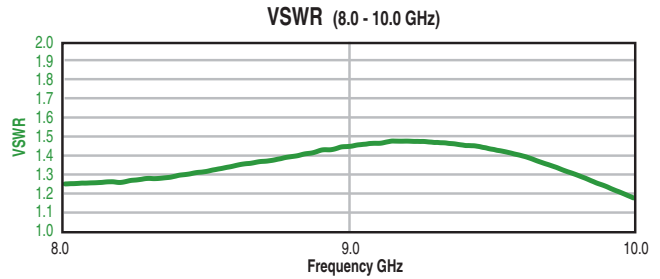
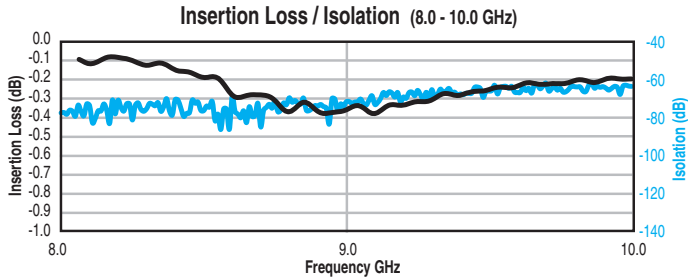
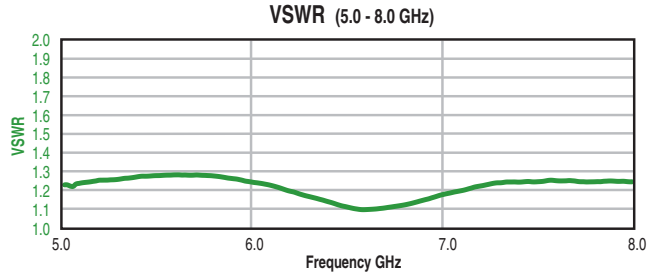
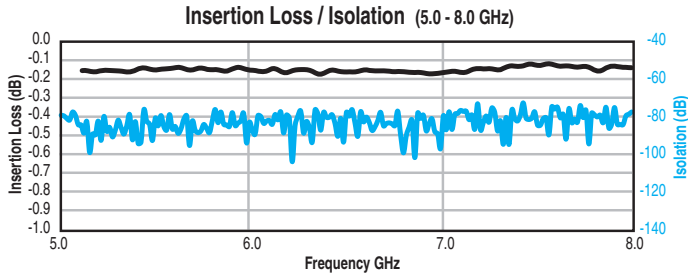
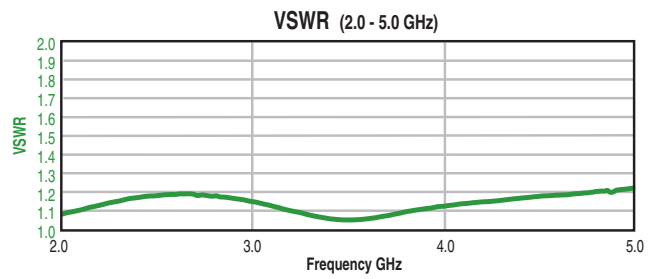
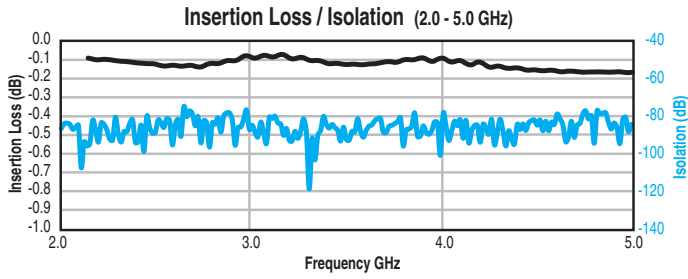
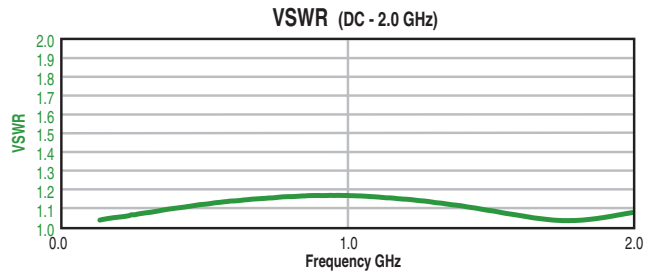
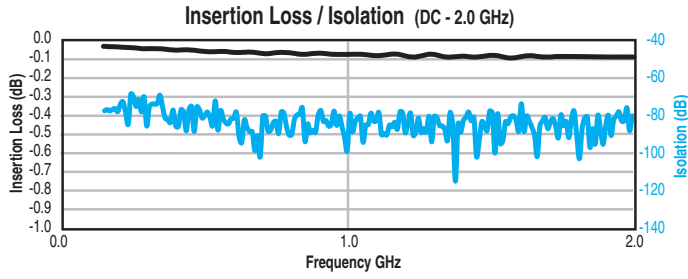

TRANSFER SWITCHES

CCR-48K, CCR-38/CR-38, CCR-58/CR-58

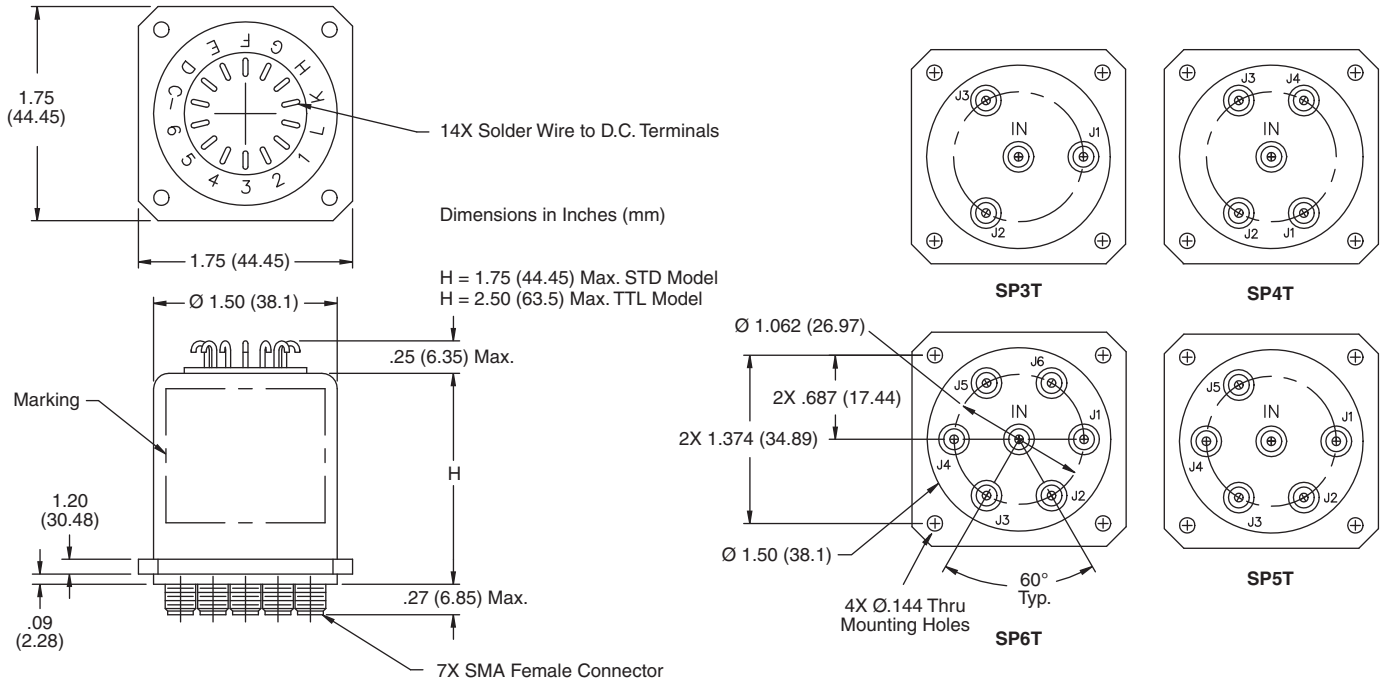

CCT-38/CT-38, CCT-58/CT-58, CCR-39/CR-39, CCT-39/CT-39, CCR-59/CR-59, CCT-59/CT-59

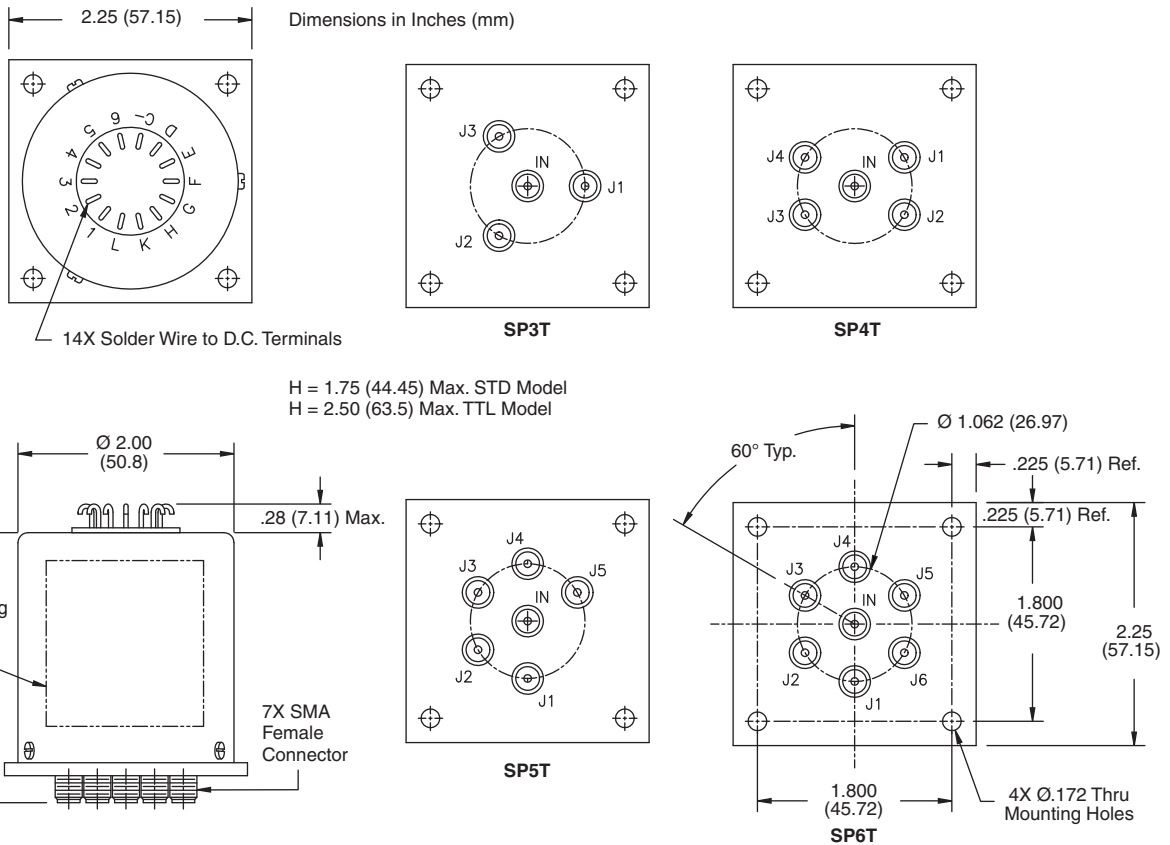

MULTI-THROW SWITCHES

CCR-38/CR-38, CCR-58/CR-58, CCR-39/CR-39, CCR-59/CR-59, CCT-38/CT-38, CCT-58/CT-58, CCT-39/CT-39, CCT-59/CT-59

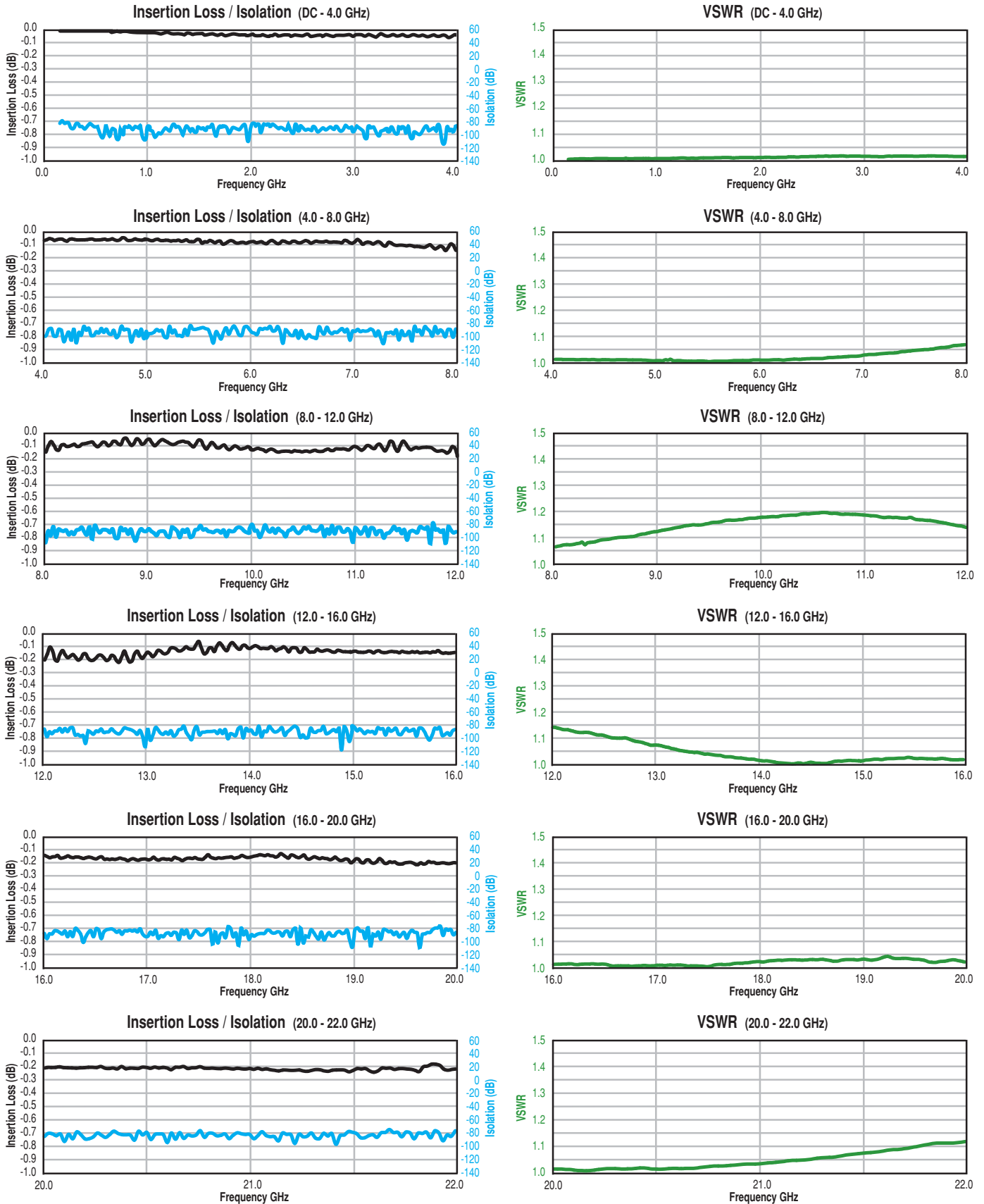

MULTI-THROW SWITCHES

CCR-38, CCT-38 SP8-10T

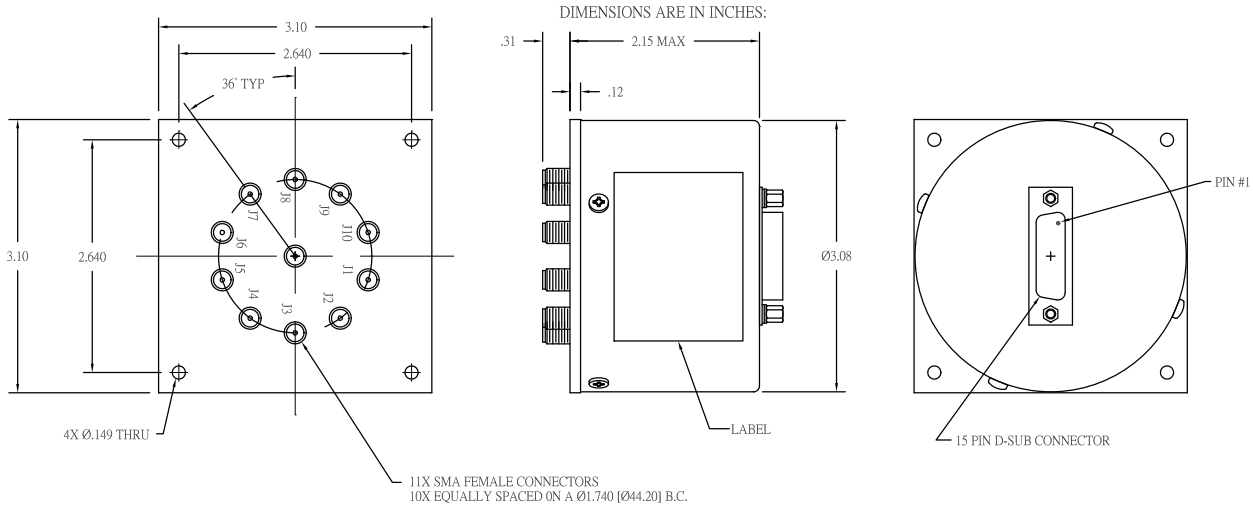
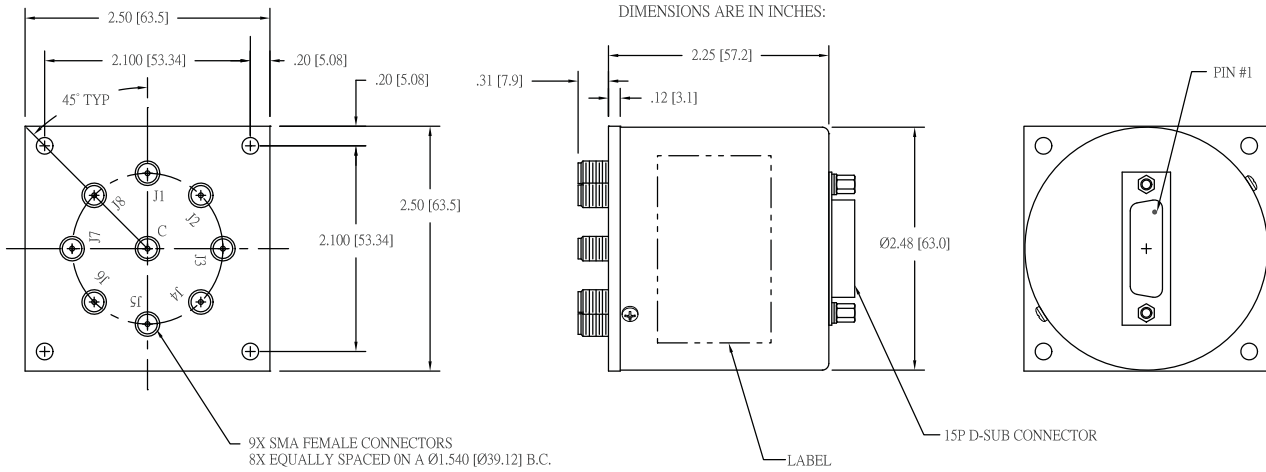

MULTI-THROW SWITCHES

SP7T & SP8T RF Performance

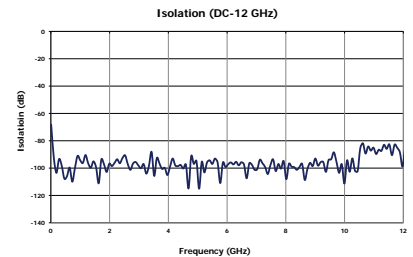
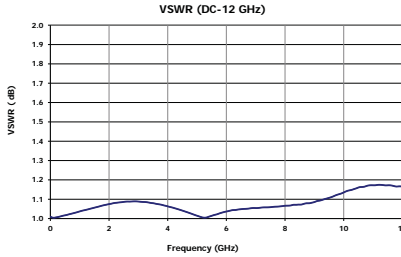
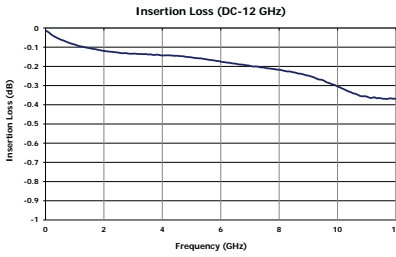

SP9T & SP10T RF Performance

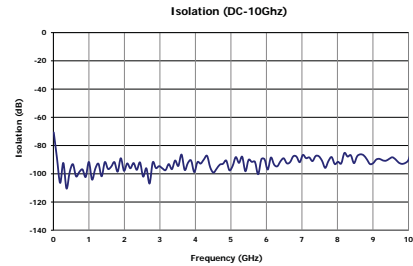
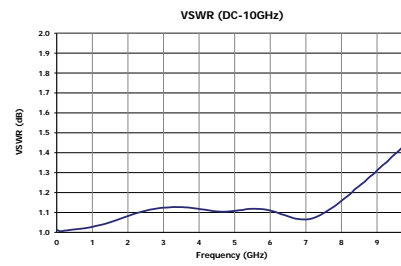
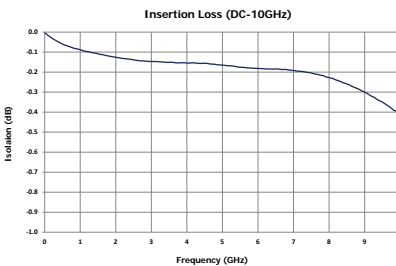

CCR-39, CCT-39 SP8-10T

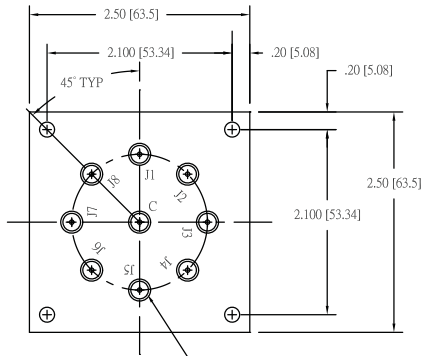

9X SMA FEMALE CONNECTORS
8X EQUALLY SPACED ON A Ø1.540 [Ø39.12] B.C.

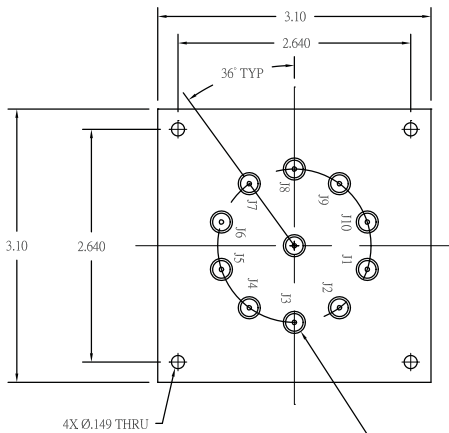
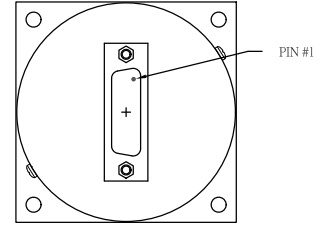
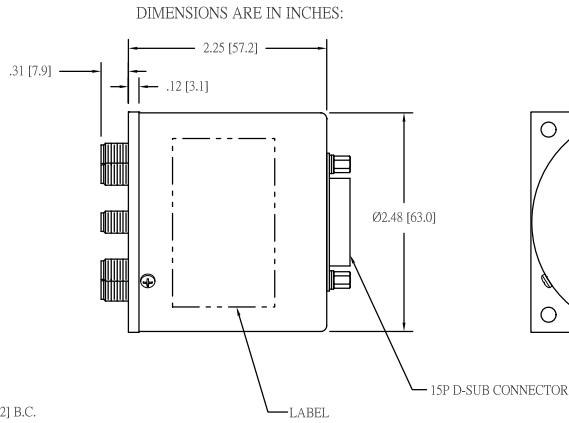

4X Ø.149 THRU

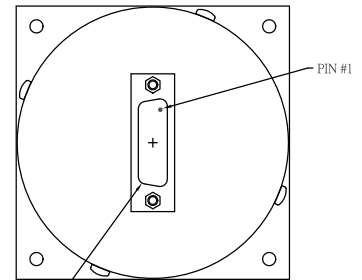
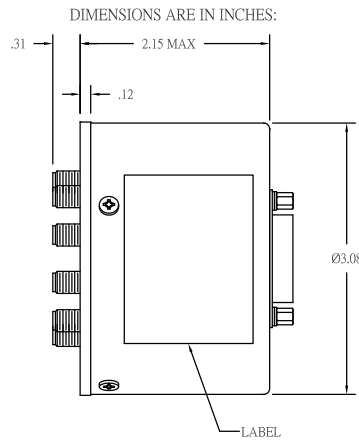

11X SMA FEMALE CONNECTORS
10X EQUALLY SPACED ON A Ø1.740 [Ø44.20] B.C.

SP7T & SP8T RF Performance

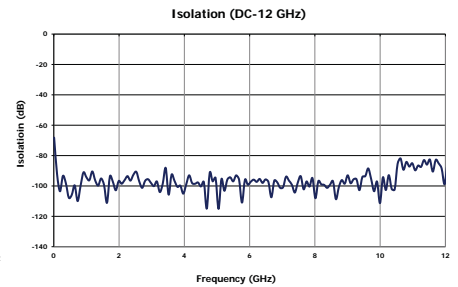
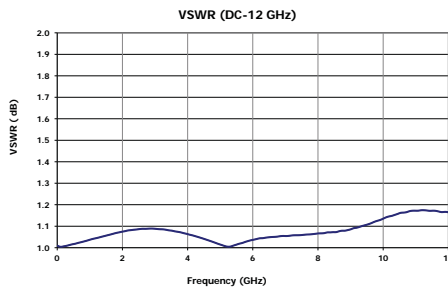
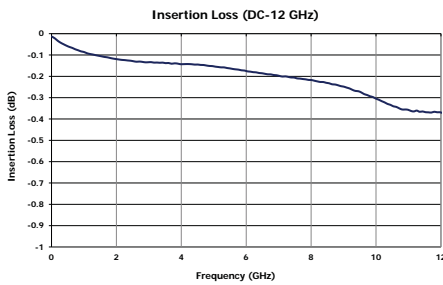

SP9T & SP10T RF Performance

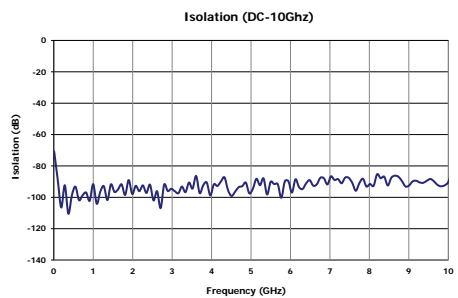
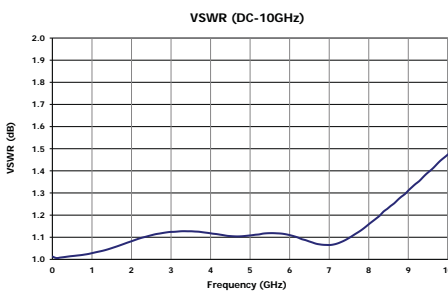
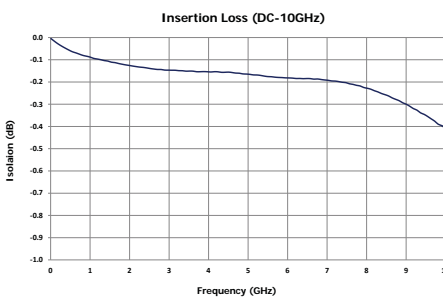

CCS-18/CS-18

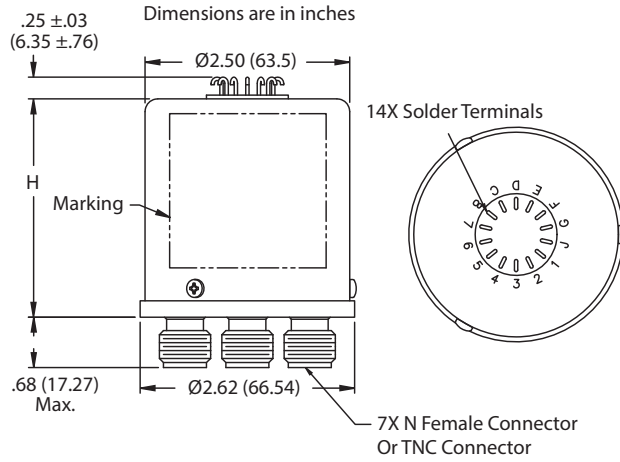

H = 2.15 (54.61) Max. Standard Model
 H = 2.65 (67.31) Max. TTL Model

MULTI-THROW SWITCHES

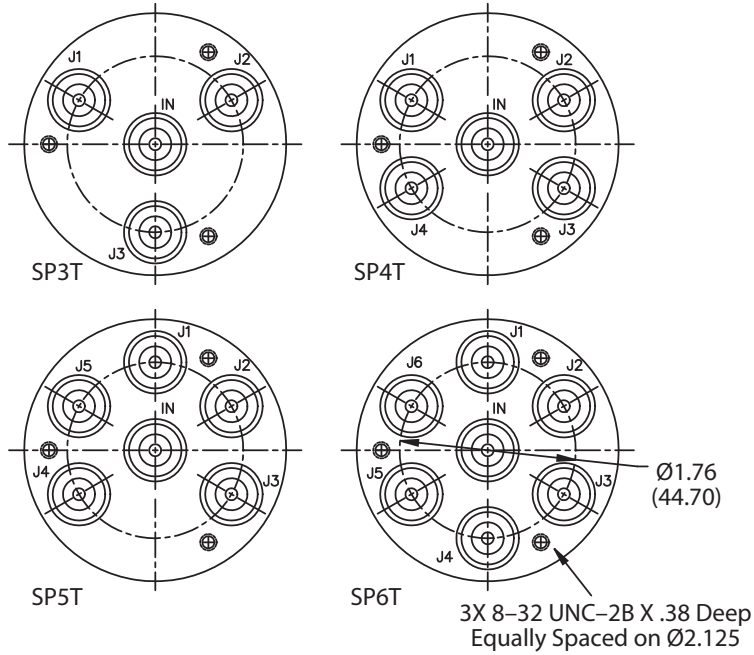

CCS-18/CS-18

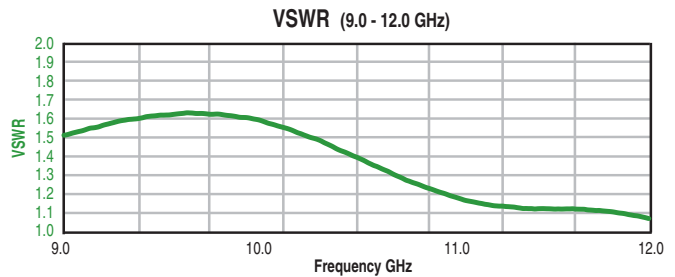
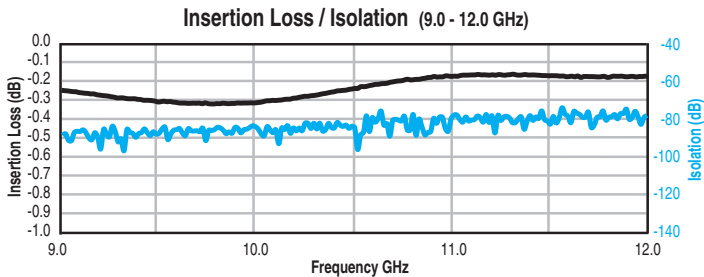
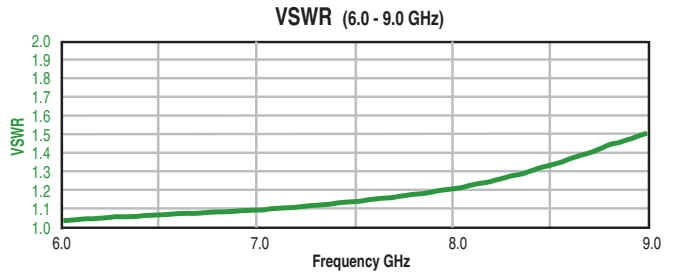
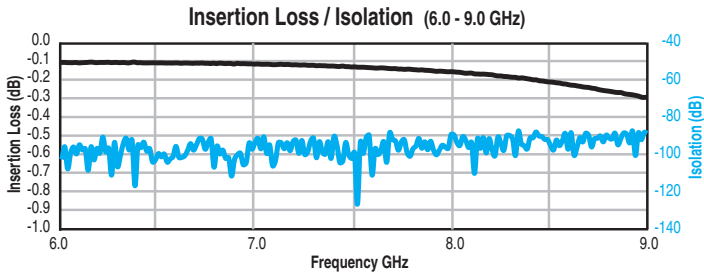
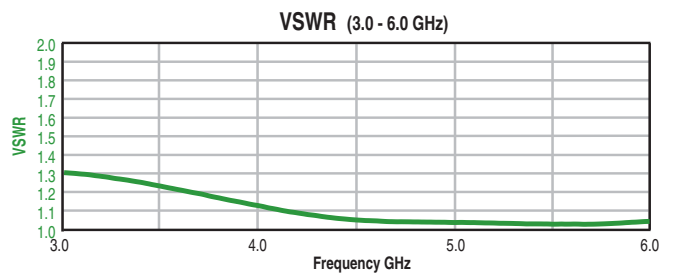
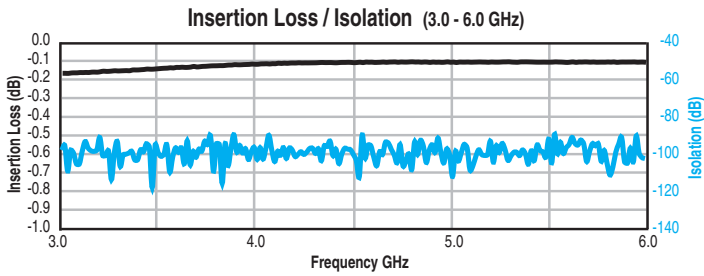
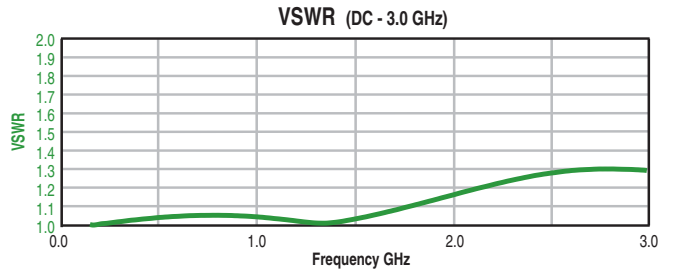
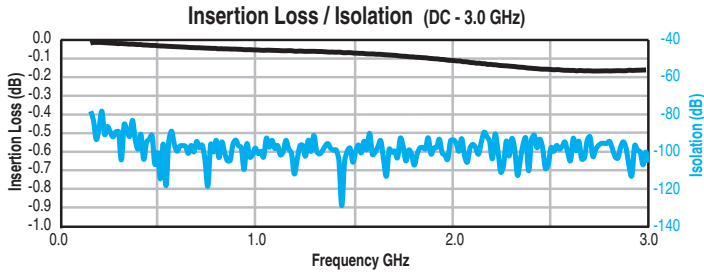

MULTI-THROW SWITCHES

CCS-19/CS-19

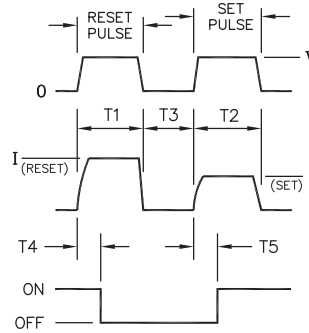
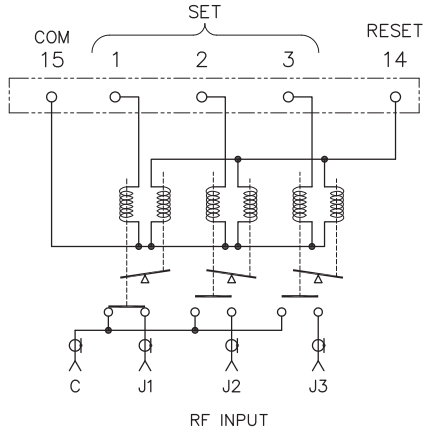

ACTUATION CHARACTERISTICS:

- REQUIRES TWO (2) SEQUENTIAL PULSES (RESET & SET)
- T1 & T2 = 30 mSEC MIN
- T3 = 10 mSEC MIN
- T4 & T5 = 20 mSEC MAX

MULTI-THROW SWITCHES

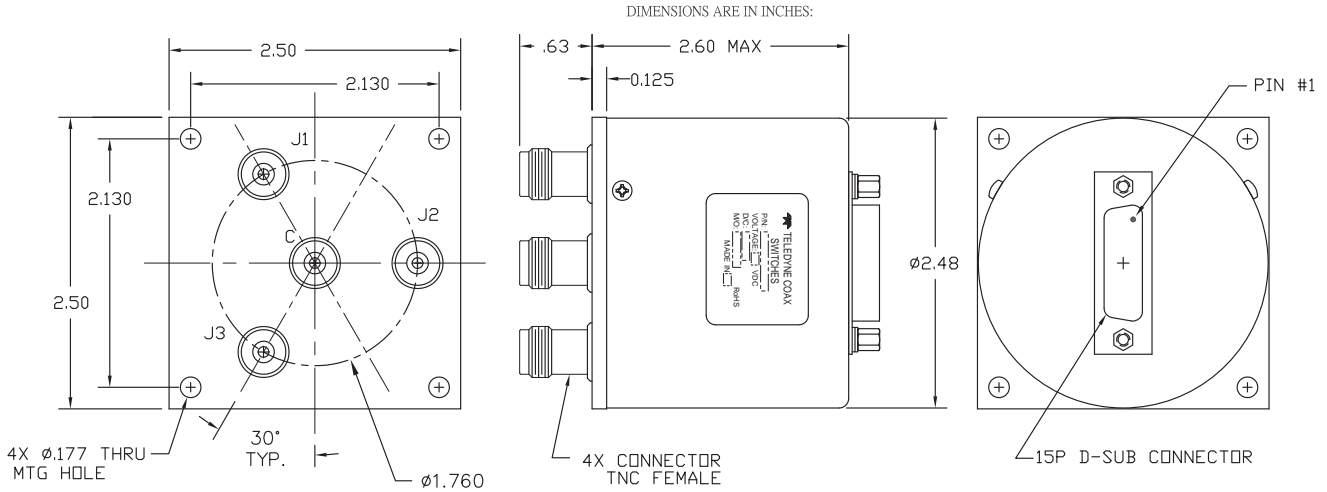

CCS-19/CS-19

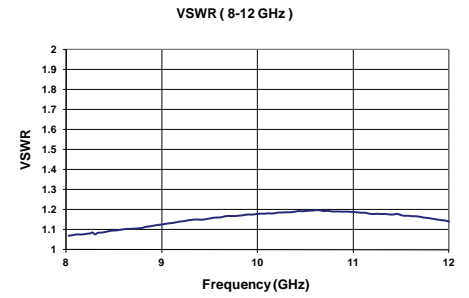
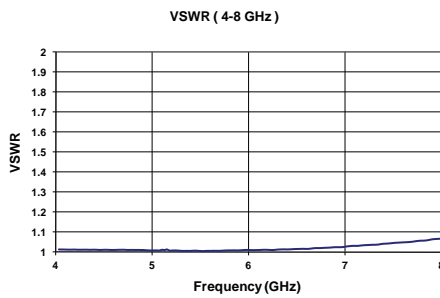
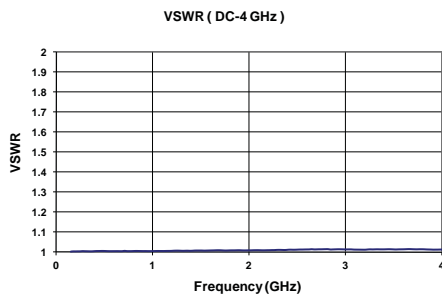
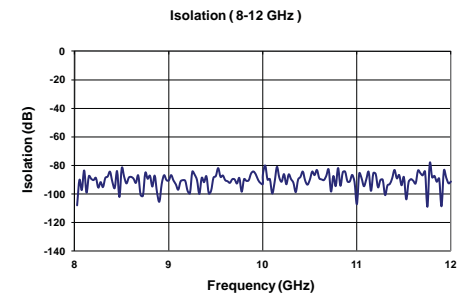
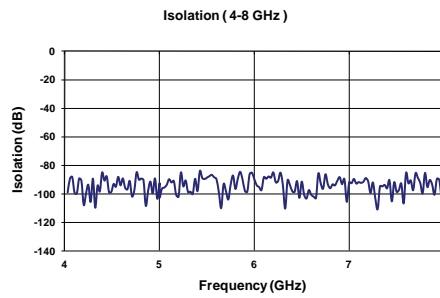
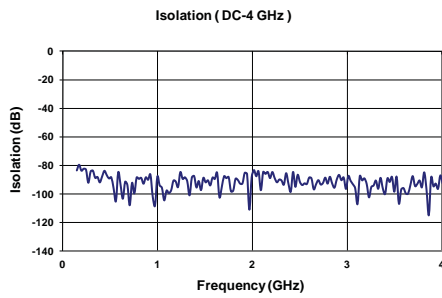
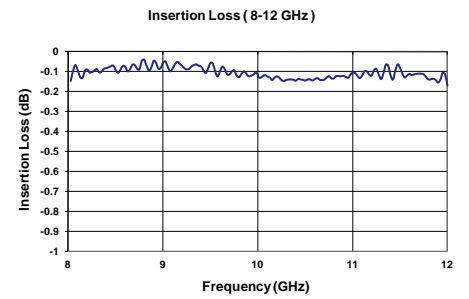
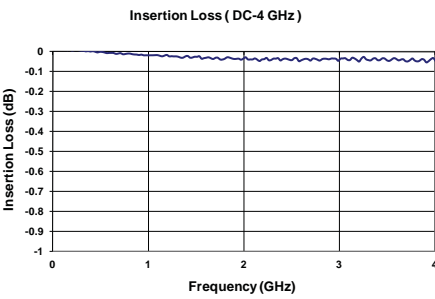

MULTI-THROW SWITCHES

CCP-33S

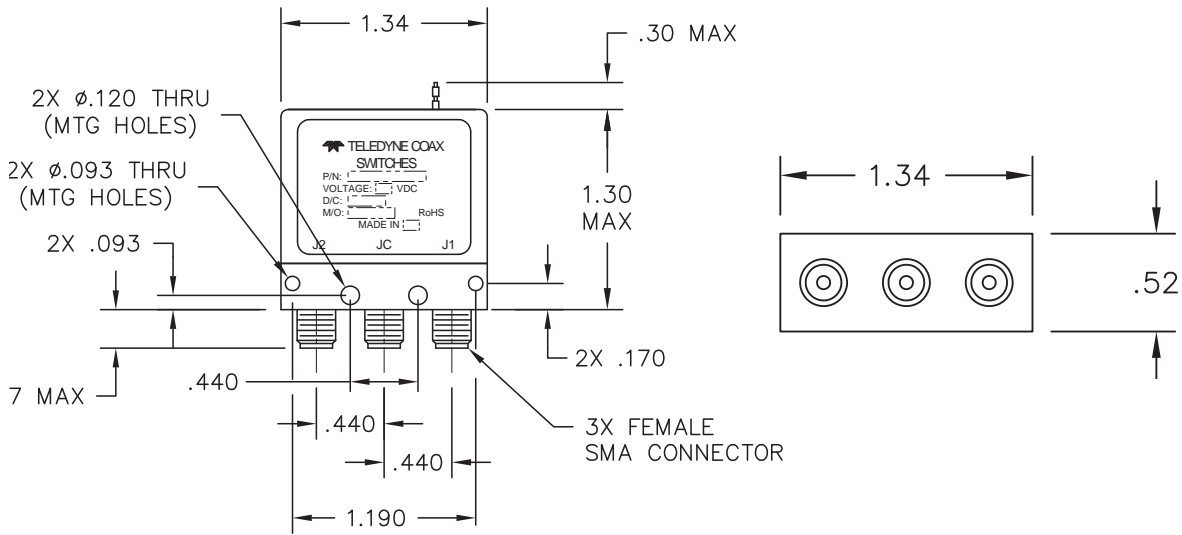

DIMENSIONS ARE IN INCHES:

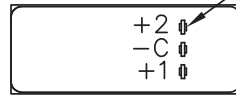
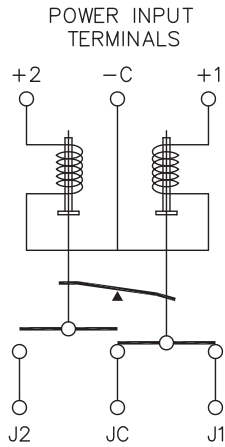

3X SOLDER D.C. WIRES TO TERMINALS MAXIMUM TEMP 250°C FOR NO MORE THAN 5 SEC

SCHEMATIC

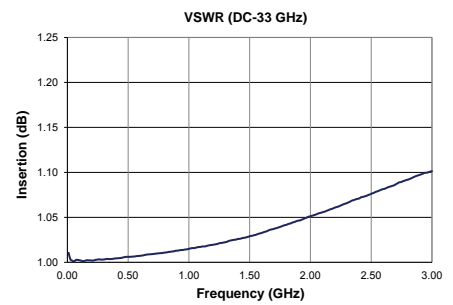
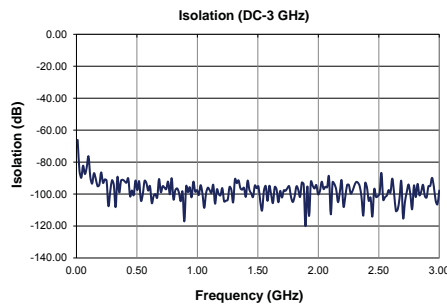
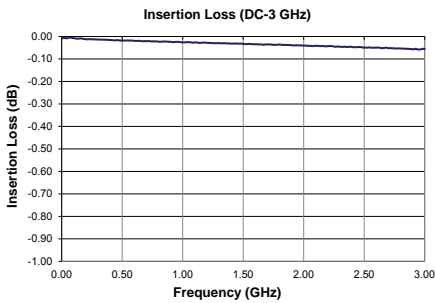

CCP-33N

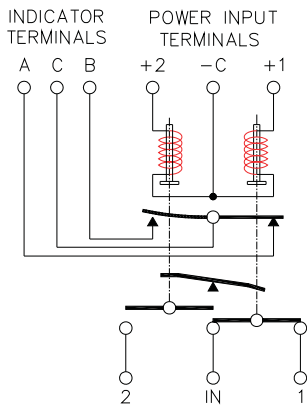

Indicators

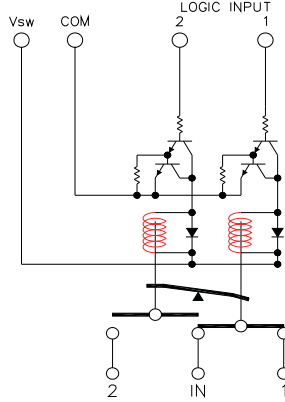

TTL

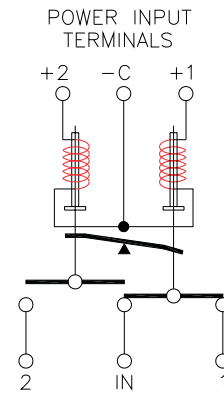

Analog

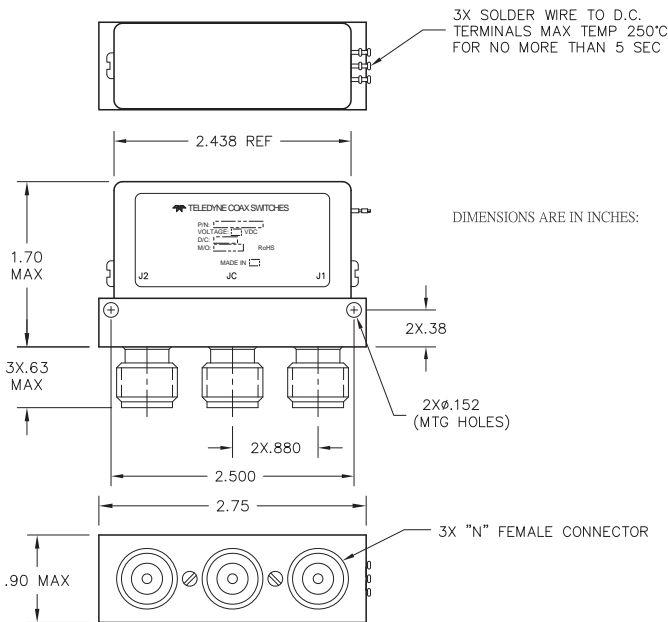

DIMENSIONS ARE IN INCHES:

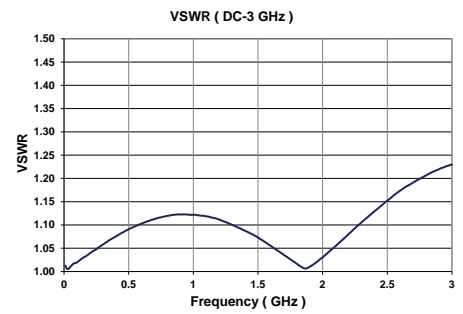
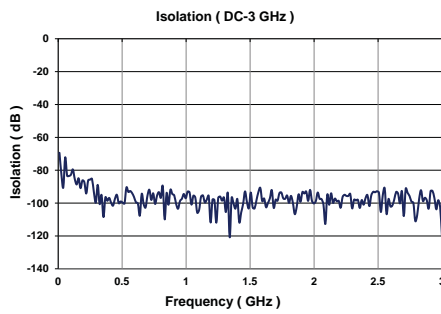
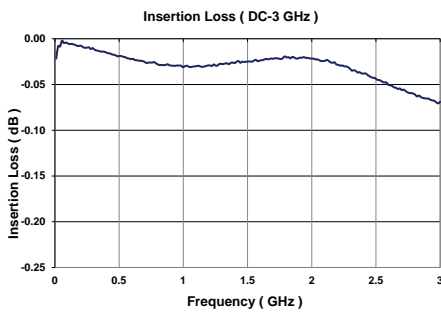
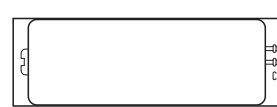
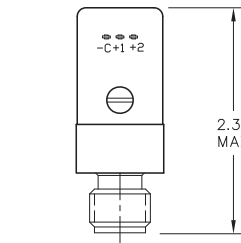

CCP-33D

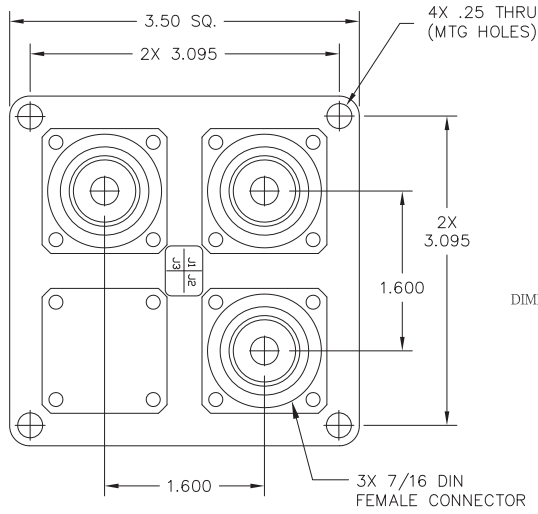

DIMENSIONS ARE IN INCHES:

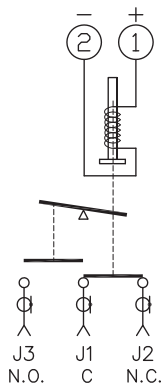
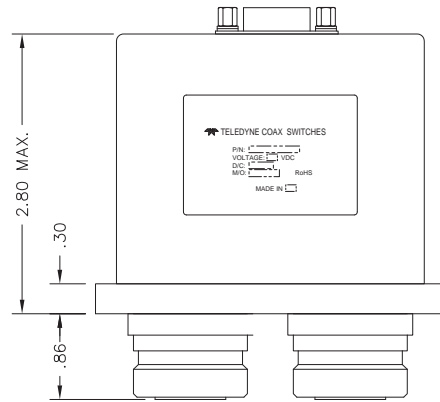

SCHMATIC

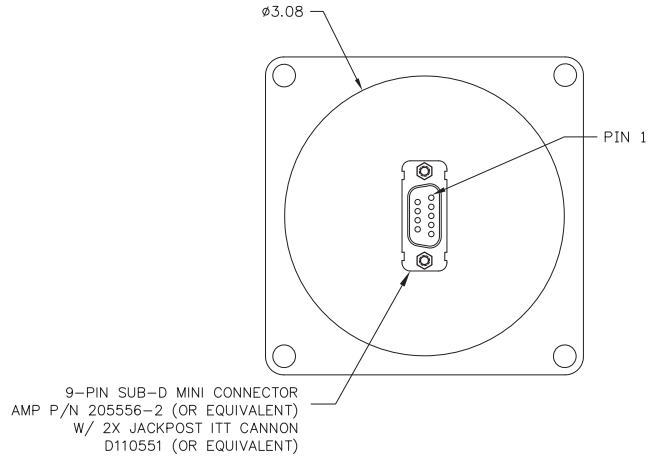

LOW PIM SWITCHES

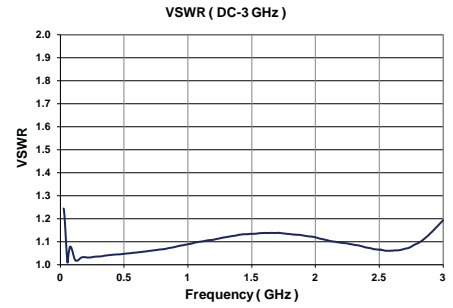
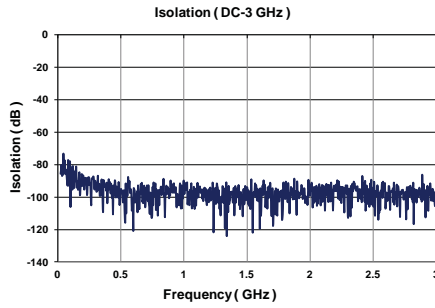
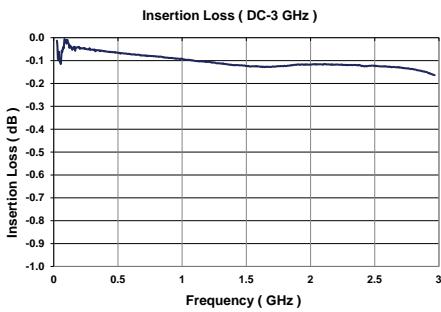

CCP-37S

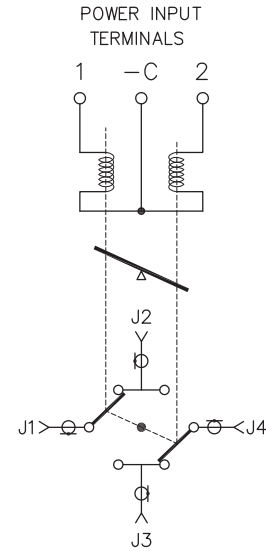
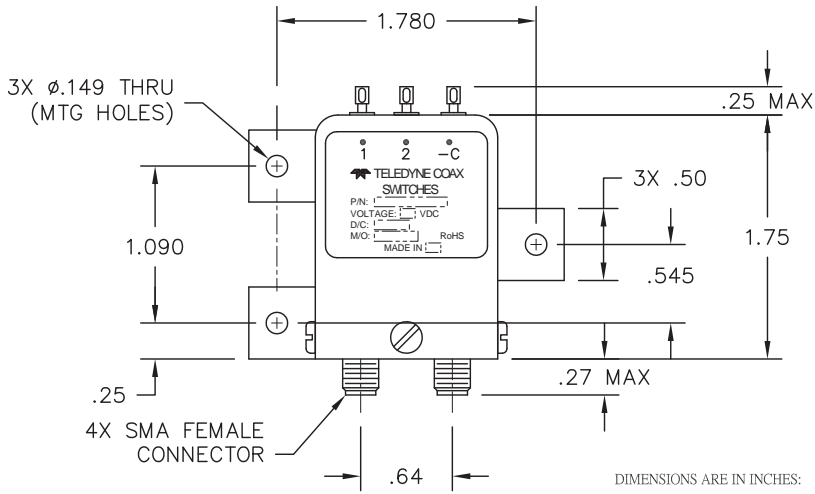

SCHEMATIC

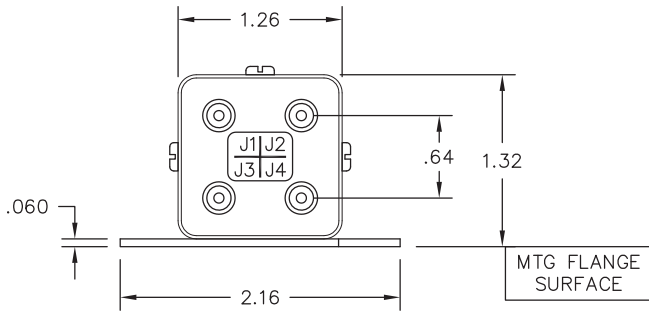

3X SOLDER WIRE TO D.C. TERMINALS MAX TEMP 250°C FOR NO MORE THAN 5 SEC

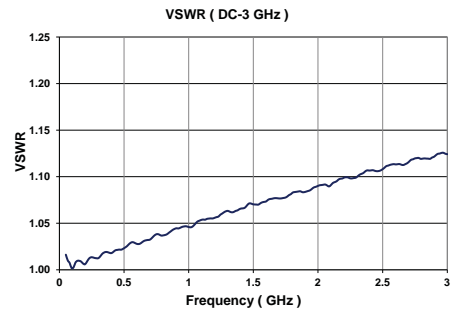
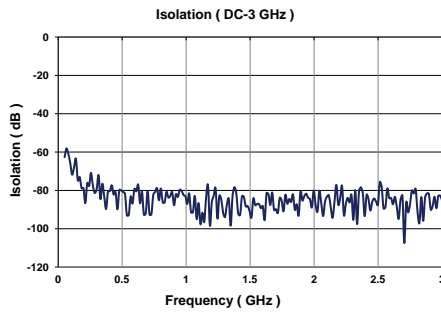
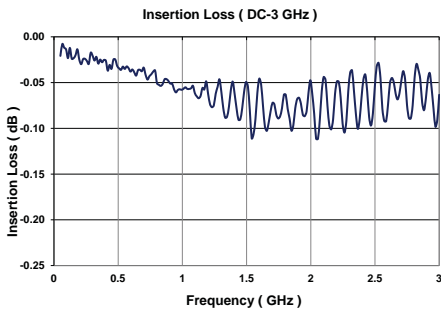
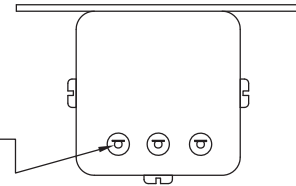

CCP-47N

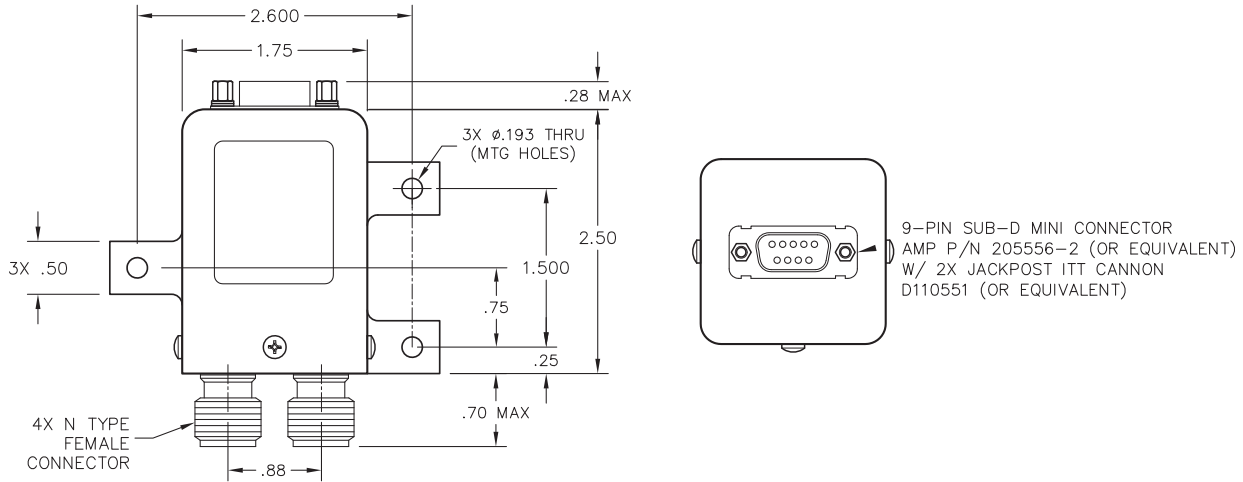

DIMENSIONS ARE IN INCHES:

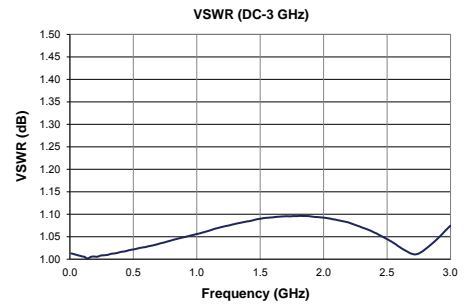
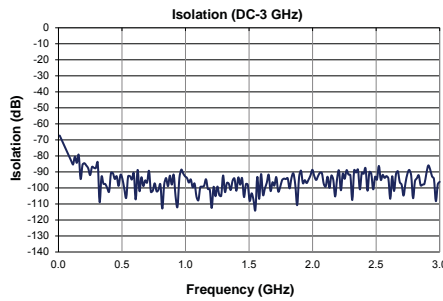
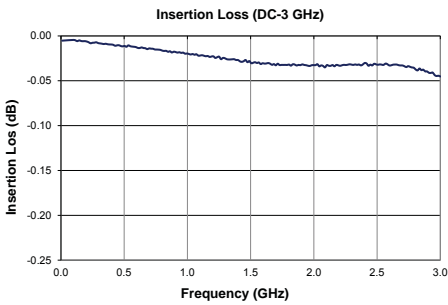
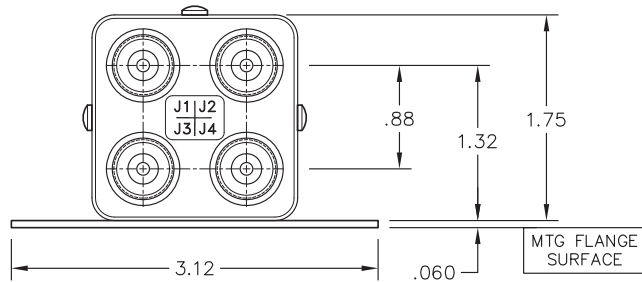
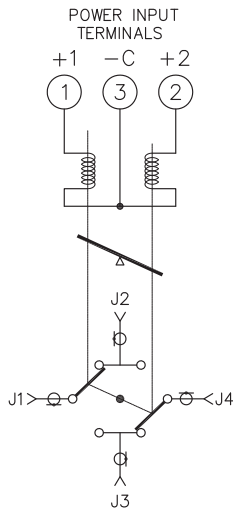

CCP-47D

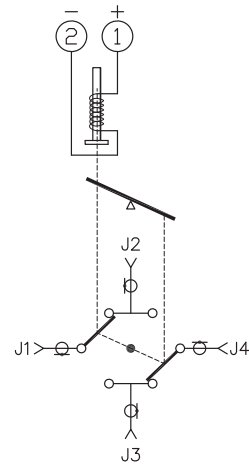
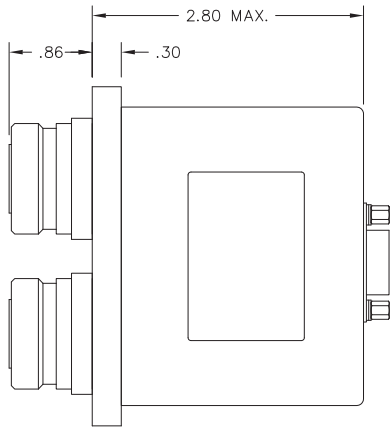

SCHEMATIC

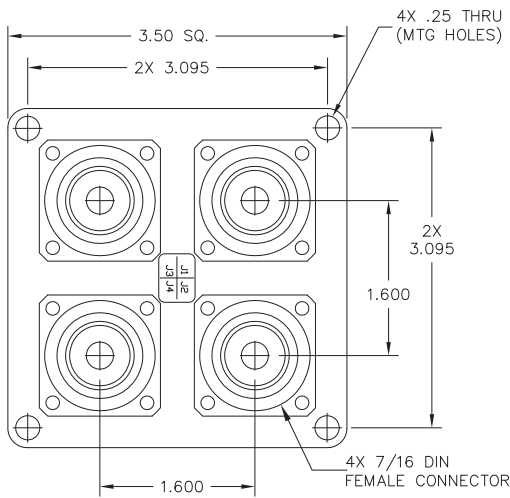

DIMENSIONS ARE IN INCHES:

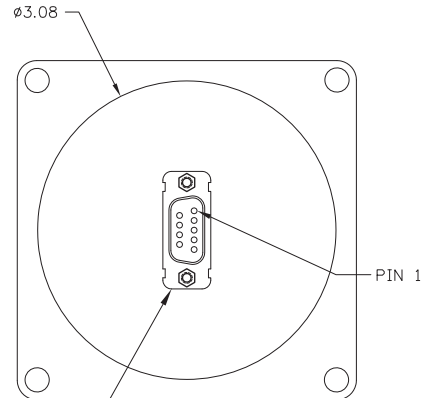

3-PIN SUB-D MINI CONNECTOR
'N 205556-2 (OR EQUIVALENT)
W/ 2X JACKPOST ITT CANNON
D110551 (OR EQUIVALENT)

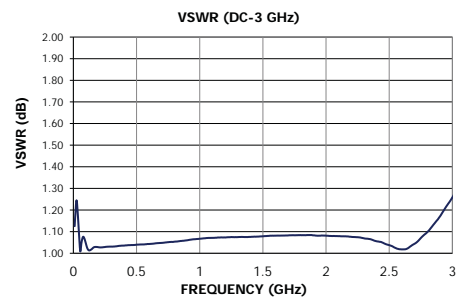
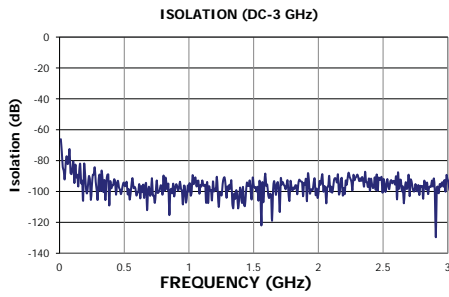
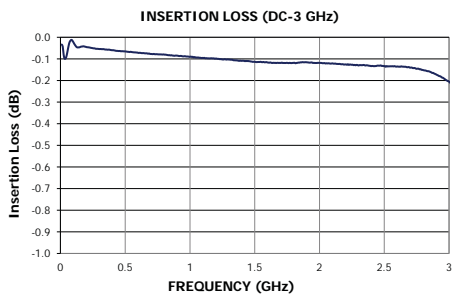

LOW PIM SWITCHES

CCP-18D

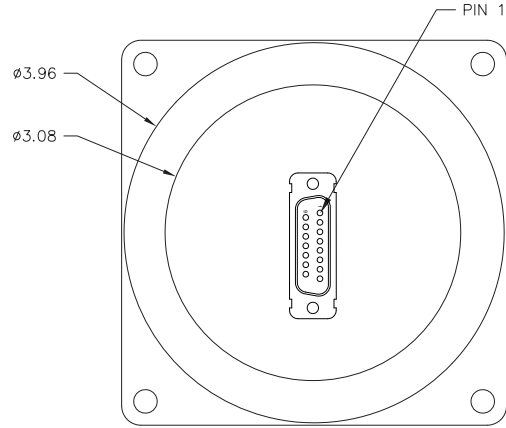
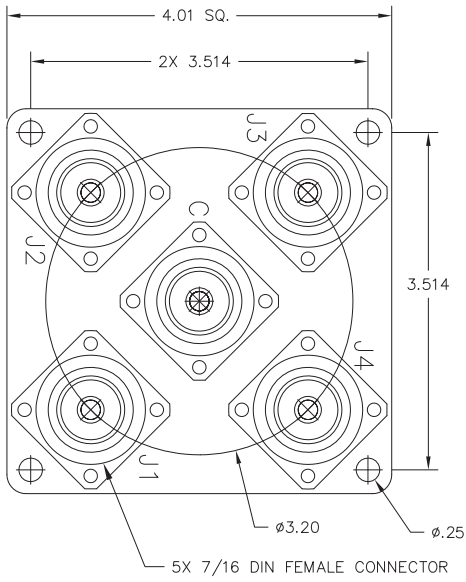

DIMENSIONS ARE IN INCHES:

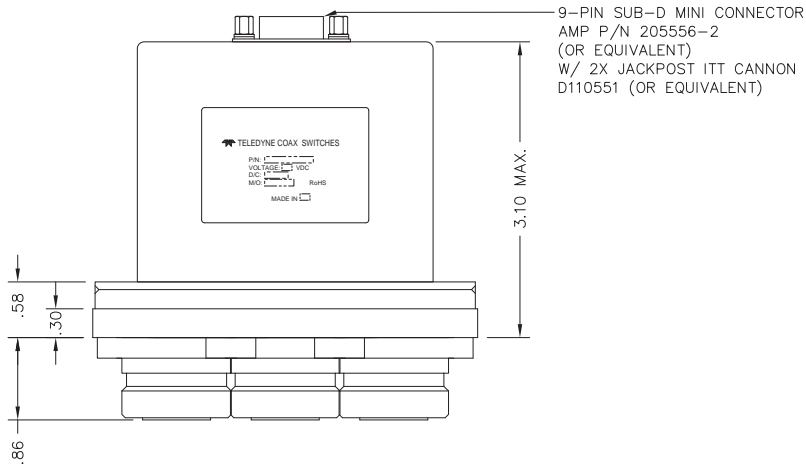

9-PIN SUB-D MINI CONNECTOR
AMP P/N 205556-2
(OR EQUIVALENT)
W/ 2X JACKPOST ITT CANNON
D110551 (OR EQUIVALENT)

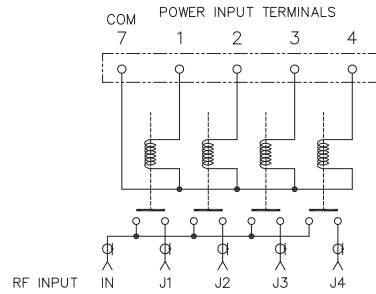

SCHEMATIC
SHOWN IN
NORMALLY OPEN POSITION

Insertion Loss (DC-3 GHz)

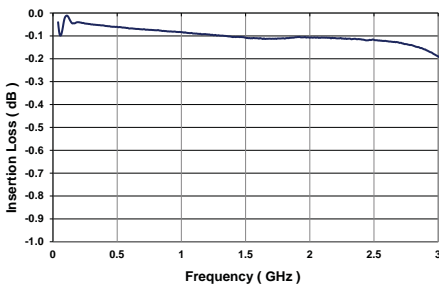

Isolation (DC-3 GHz)

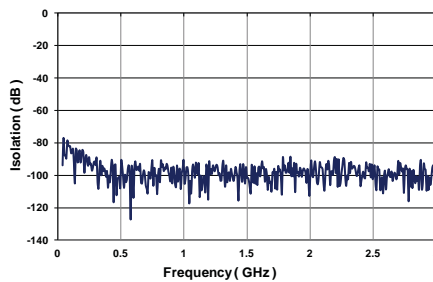

VSWR (DC-3 GHz)

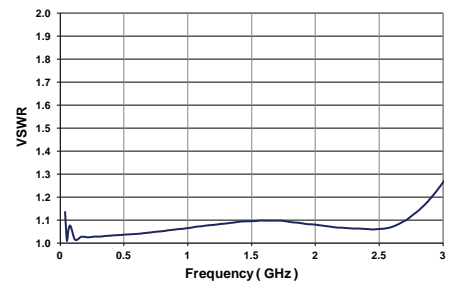

CCP-38S

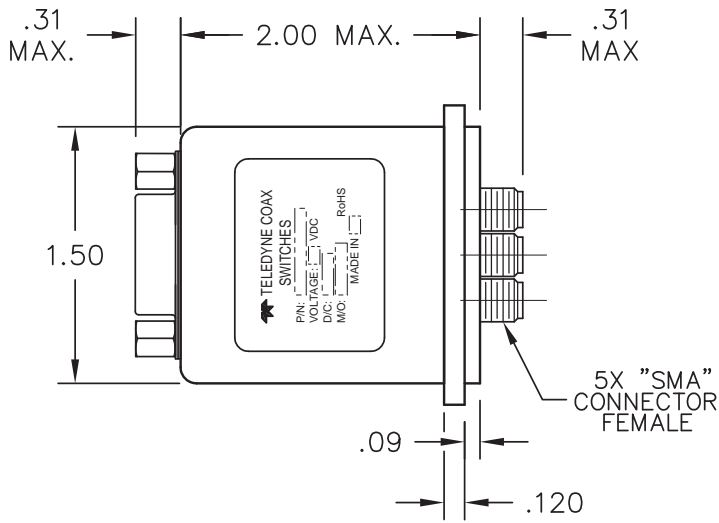

DIMENSIONS ARE IN INCHES:

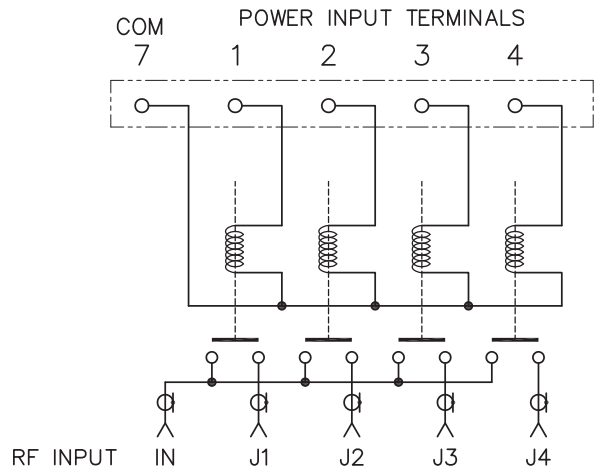
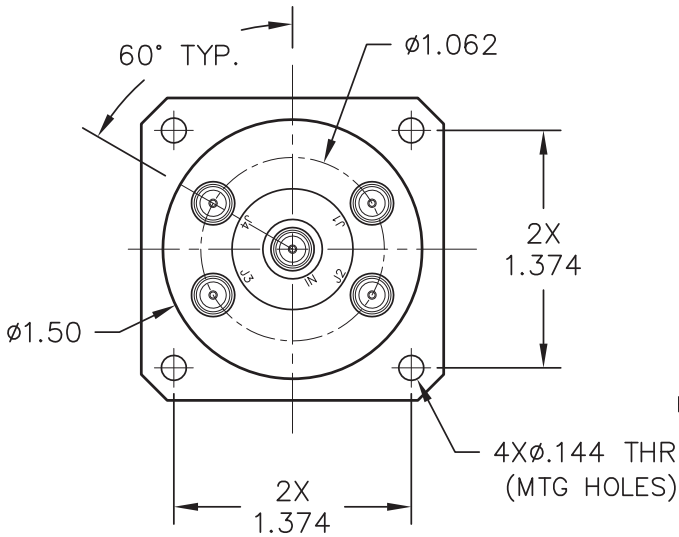
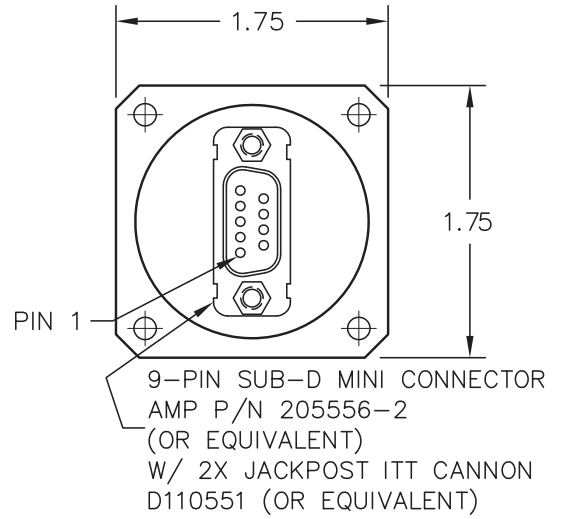

SCHEMATIC

SHOWN IN
NORMALLY OPEN POSITION

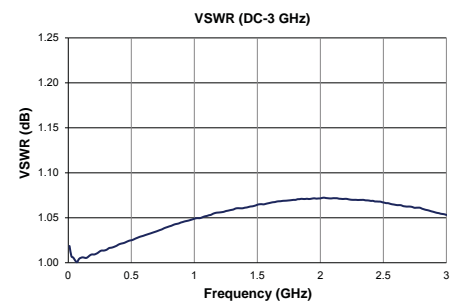
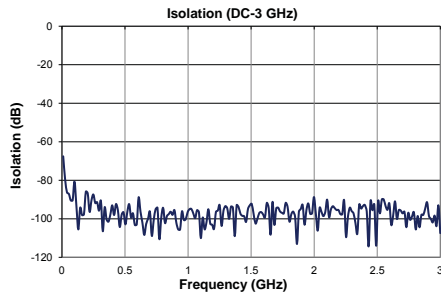
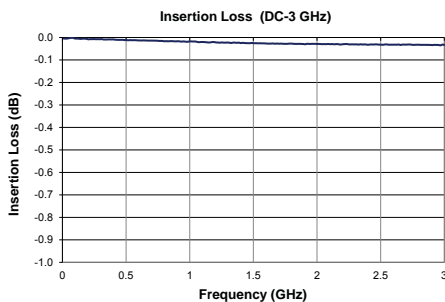

CCP-18N

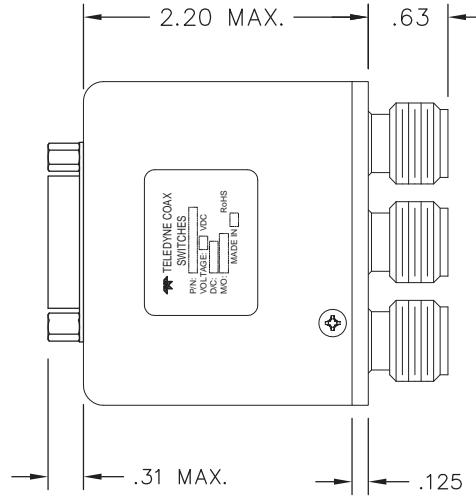
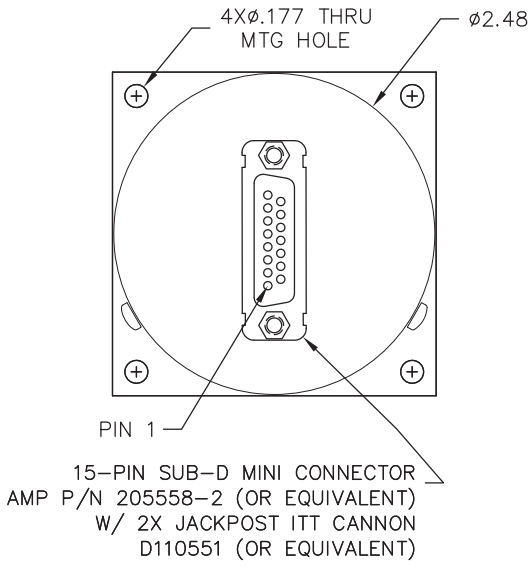

DIMENSIONS ARE IN INCHES:

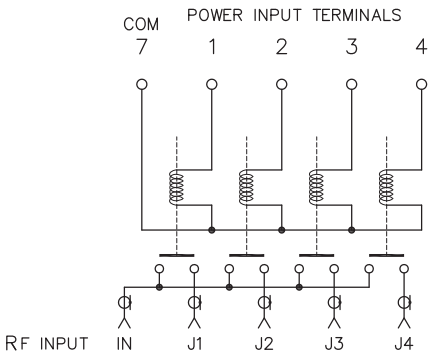

SCHMATIC

SHOWN IN NORMALLY OPEN POSITION

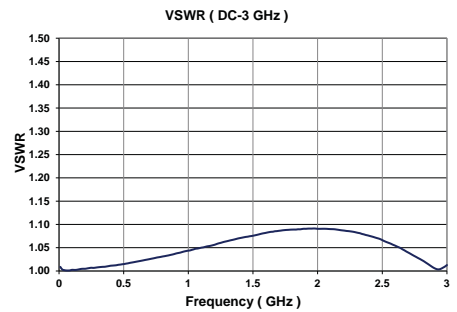
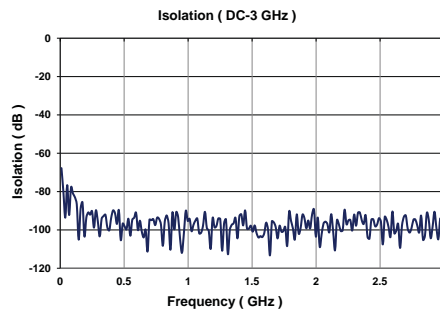
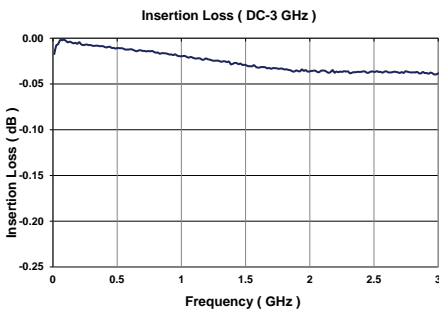
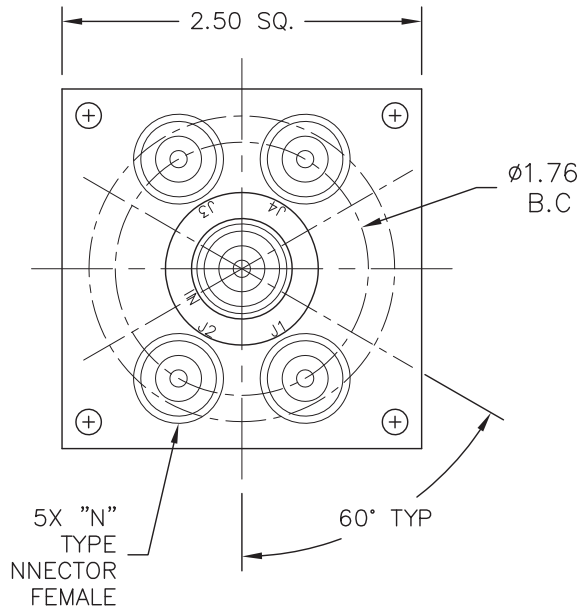

LOW PIM SWITCHES

CAS-37

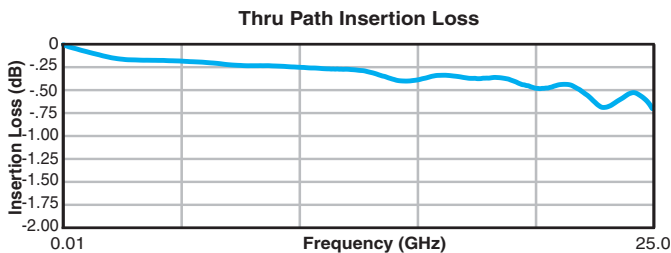
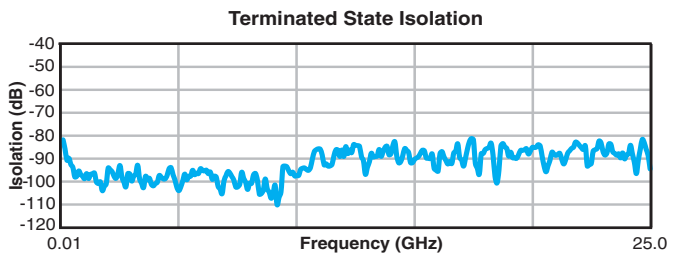
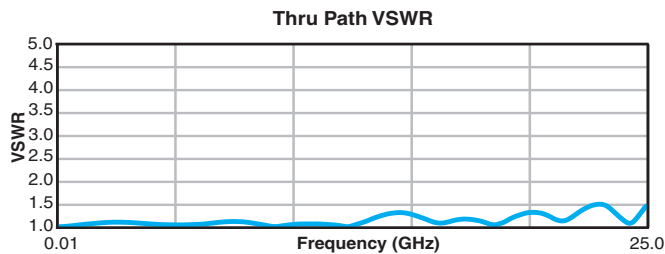
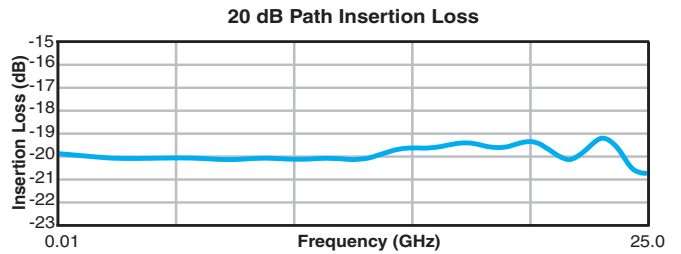
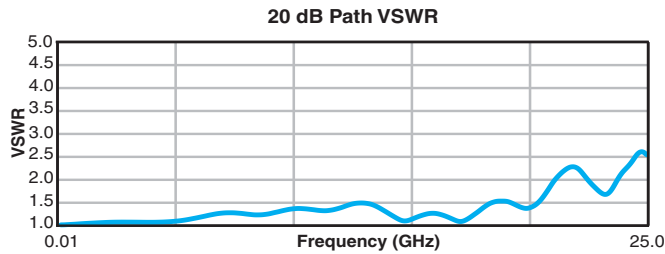
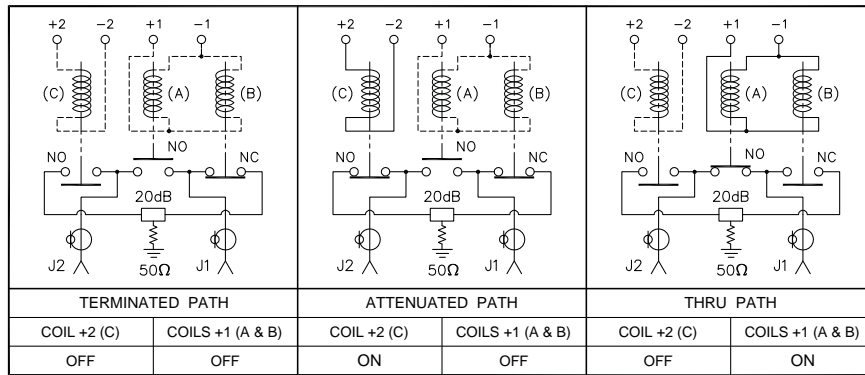
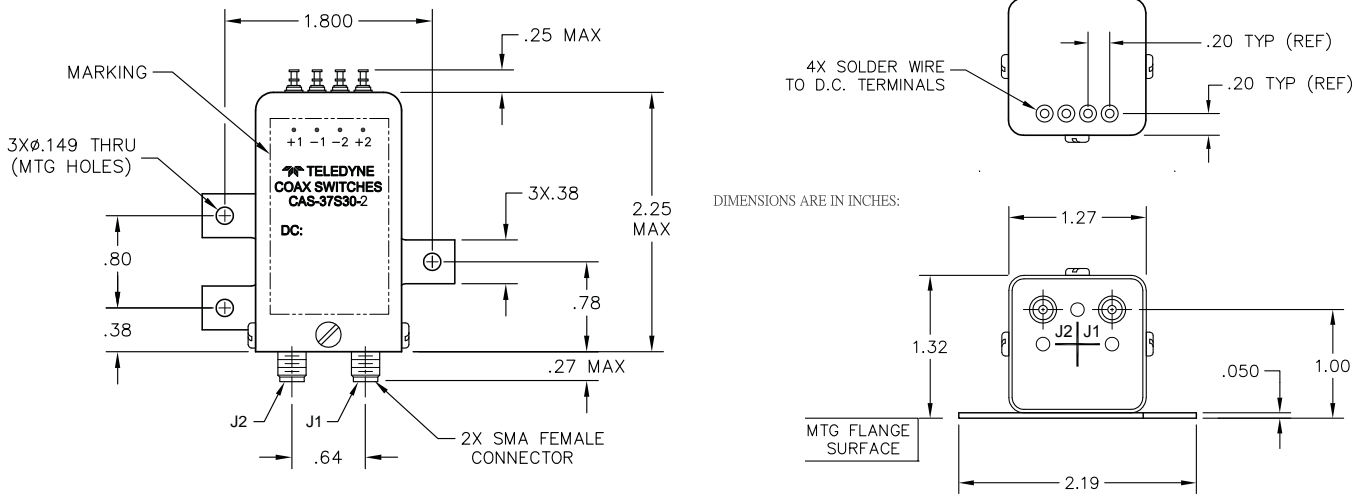

SPECIALTY SWITCHES

Coaxial Switches

Power Handling vs. Frequency

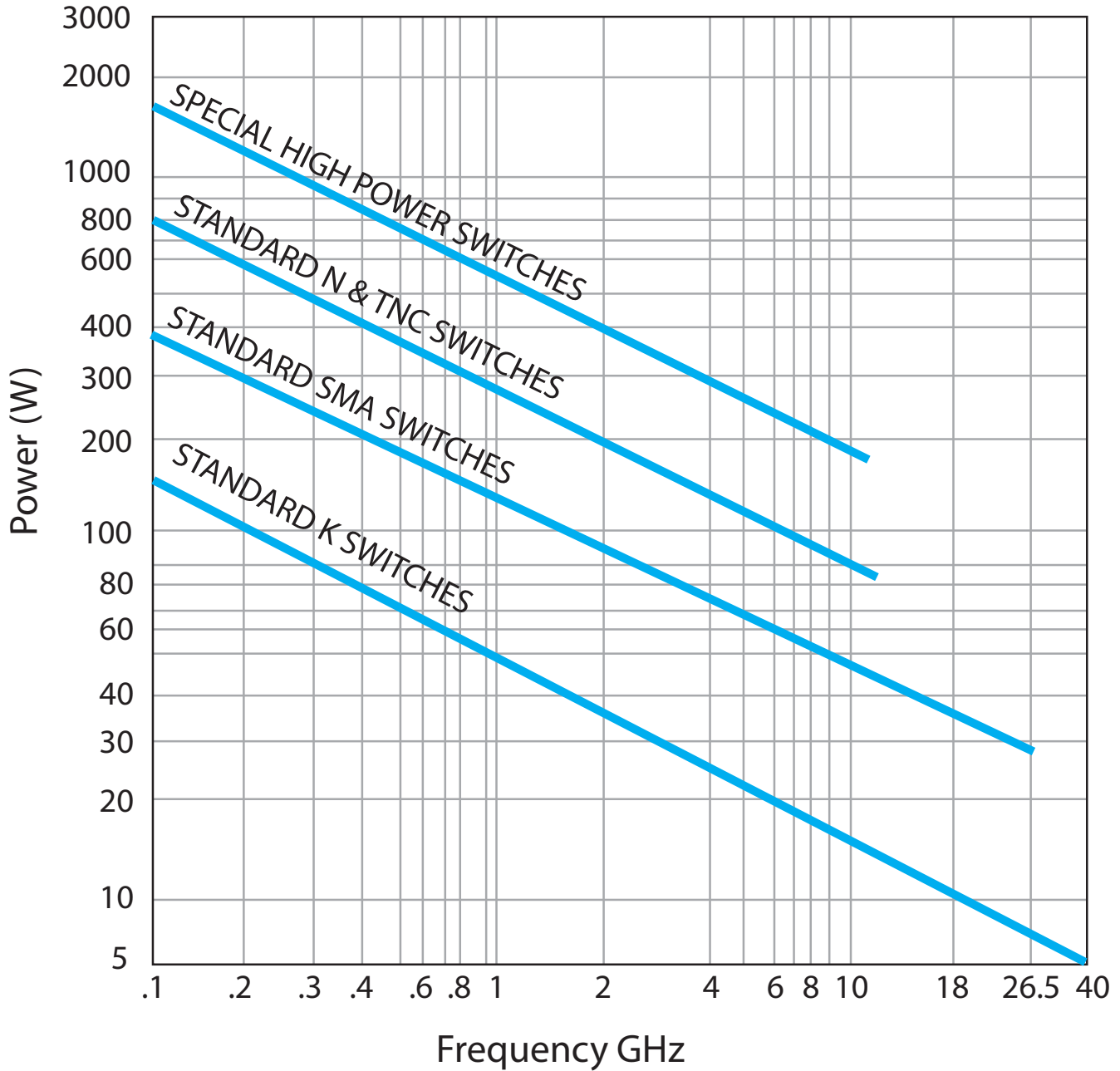

Estimates based on the following reference conditions:

- Ambient temperature of 40°C or less
- Sea level operation
- Load VSWR of 1.20:1 maximum
- No high-power (hot) switching

Please contact Teledyne Coax Switches for derating factors when applications do not meet the foregoing reference conditions.

Teledyne Coax Switches

Insertion Loss Repeatability

SPDT Coaxial Switch 10 M Cycles Insertion Loss Repeatability (Contact 1)

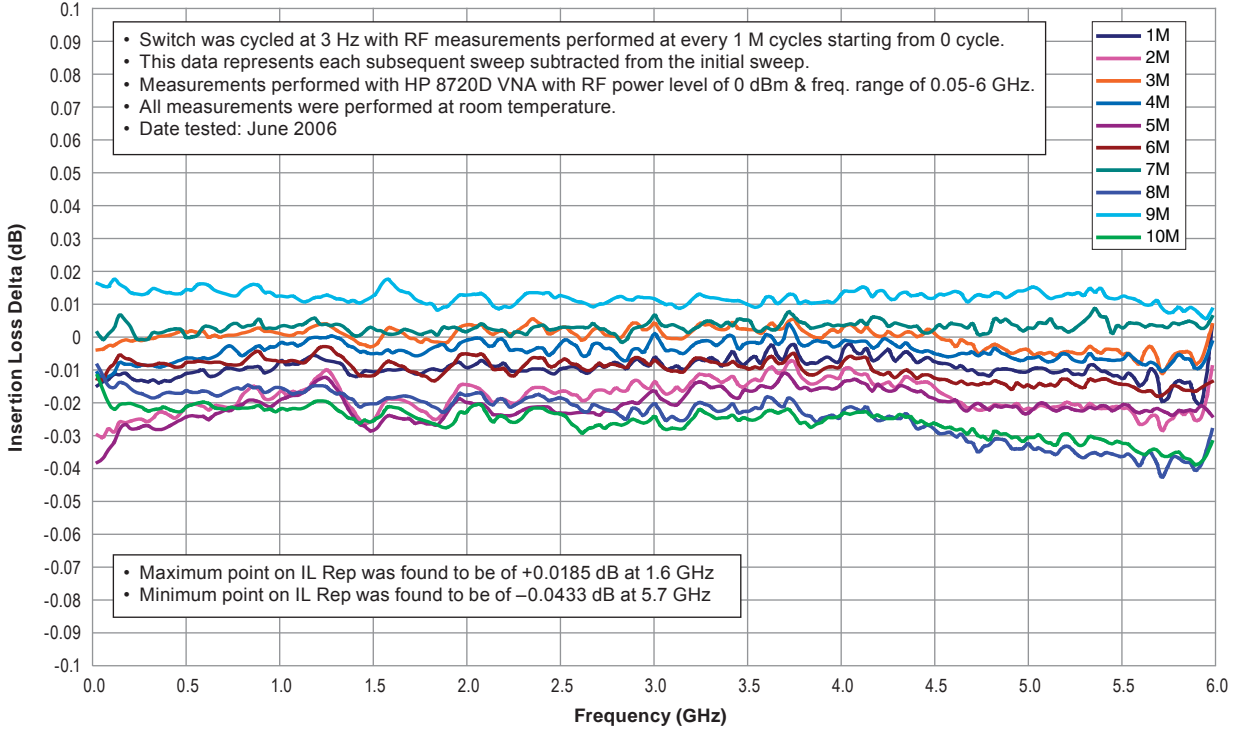

SPDT Coaxial Switch 10 M Cycles Insertion Loss Repeatability (Contact 2)

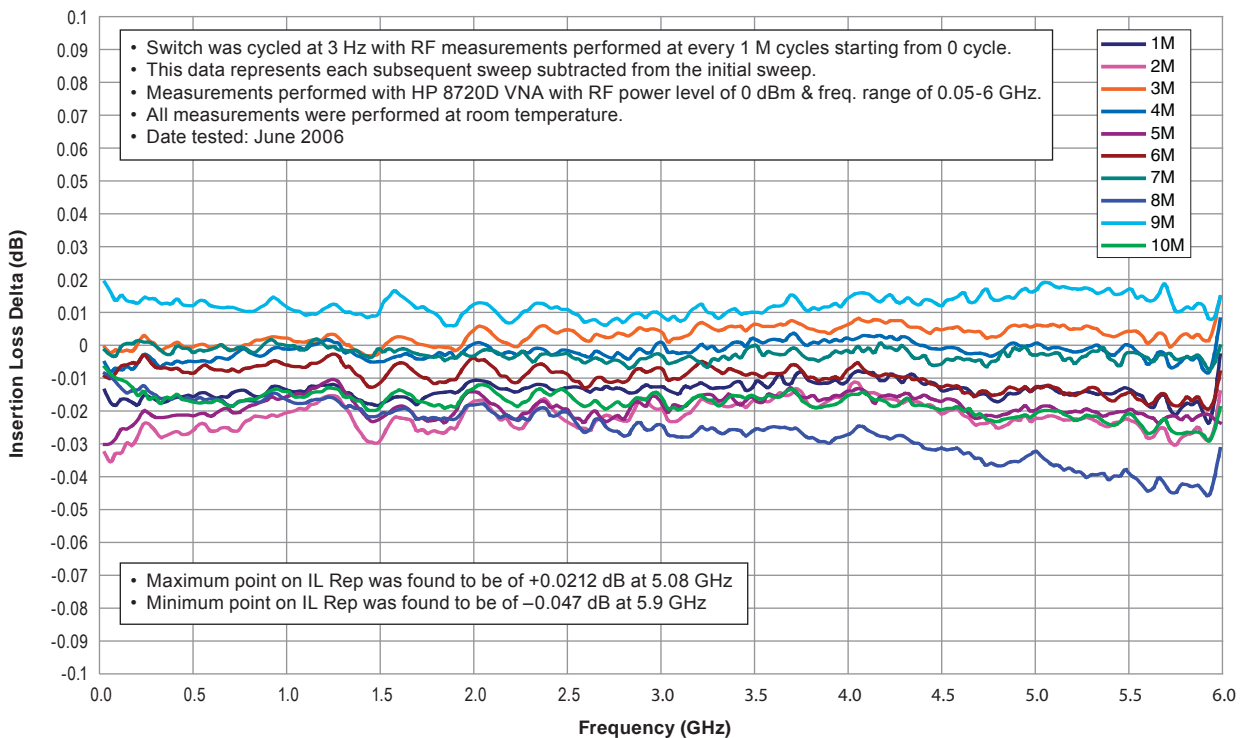

Actuator

An actuator is the electromechanical mechanism that transfers the RF contacts from one position to another upon DC command.

Arc Suppression Diode

A diode is connected in parallel with the coil. This diode limits the “reverse EMF spike” generated when the coil de-energizes to 0.7 volts. The diode cathode is connected to the positive side of the coil and the anode is connected to the negative side.

Date Code

All switches are marked with either a unique serial number or a date code. Date codes are in accordance with MIL-STD-1285 Paragraph 5.2.5 and consist of four digits. The first two digits define the year and the last two digits define the week of the year (YYWW). Thus, 0532 identifies switches that passed through final inspection during the 32nd week of 2005.

Failsafe

A failsafe switch reverts to the default or failsafe position when the actuating voltage is removed. This is realized by a return spring within the drive mechanism. This type of switch requires the continuous application of operating voltage to select and hold any position. (Multi-position switches are normally open with no voltage applied).

Latching

A latching switch remains in the selected position whether or not voltage is maintained. This can be accomplished with either a magnetic or mechanical latching mechanism.

Indicator

Indicators tell the system which position the switch is in. Other names for indicators are telemetry contacts or tellback circuit. Indicators are usually a set of internally mounted DC contacts linked to the actuator. They can be wired to digital input lines, status lights, or interlocks. Unless otherwise specified, the maximum indicator contact rating is 30 Vdc, 50 mA, or 1.5 Watts into a resistive load.

Internal Termination

Unselected ports are connected internally to a matched load. The load is a 50-Ohm resistive device. The max RF power rating is 2 watts CW. Without the internal termination option, the unselected ports are open circuits.

Isolation

Isolation is the measure of the power level at the output connector of an unconnected RF channel as referenced to the power at the input connector. It is specified in dB below the input power level.

Multi-Throw Switch

A multi-throw switch is a switch with one input and three or more output ports. The CCT-58 can switch a microwave signal to any of 2, 3, 4, 5 or 6 outputs from a single common input.

Multi-Throw Latching Switch

DUAL PULSE SWITCHING COMMAND CHARACTERISTICS:

1. APPLIES FOR SINGLE-POLE MULTI-THROW LATCHING SWITCH ONLY.
2. MUST APPLY RESET PULSE FIRST (BREAK-BEFORE-MAKE).
3. RESET AND SET DEFINITIONS
RESET: OPEN ALL RF PATHS (POSITIONS).
SET: CLOSE THE SELECTED RF PATH (POSITION).
4. COMMAND PULSE TIMING:

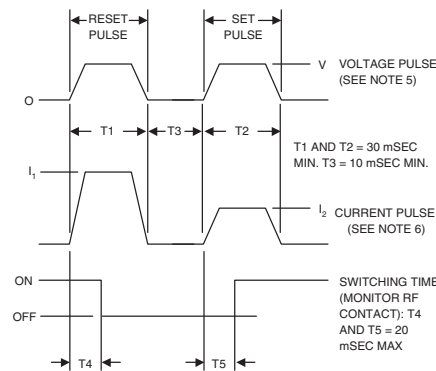

5. COMMAND SWITCHING VOLTAGE:
V = 26-32 VDC PULSE

6. SWITCHING CURRENT:

SWITCHING CURRENT AT 28 VDC AND 20°C		
NO. OF POS.	RESET (I ₁)	SET (I ₂)
3 POS.	270 mA	90 mA
4 POS.	360 mA	90 mA
5 POS.	450 mA	90 mA
6 POS.	540 mA	90 mA

Self-Cutoff

The self-cutoff option disables the actuator current on completion of actuation. Either a series contact (linked to the actuator) or an IC driver circuit provides the current cutoff. This option results in minimum power consumption by the RF switch. Cutthroat is another name used in the industry for this option. Pulse latching is a term sometimes used to describe a switch without this feature.

SPDT Switch

A single-pole double-throw switch has one input and two output ports.

Switching Time

Switching time is the total interval beginning with the arrival of the leading edge of the command pulse at the switch DC input and ending with the completion of the switch transfer, including contact bounce. It consists of three parts: (1) inductive delay in the coil, (2) transfer time of the physical movement of the contacts, and (3) the bounce time of the RF contacts.

Transfer Switch

A four-port switch consisting of two independent pairs of RF paths. These pairs are actuated simultaneously. This actuation is similar to that of a double-pole double-throw switch. See application notes for typical usage.

TTL Switch Driver Option

As a special option, switch drivers can be provided for both failsafe and latching switches, which are compatible with industry-standard low-power Schottky TTL circuits.

T-Option

This option is for TTL Driver. There is one control input for each position. See the logic table.

TD-Option

This option includes a decoder. The 3-bit parallel command is decoded to internally select the appropriate position. See the logic table.

The TD-Option increases the Vsw supply current demand by 50mA max at 28 Vdc and +20°C.

Failsafe uses 1 circuit. Latching uses 2 circuits (Vsw & C are common to both circuits).

Glossary

Performance Parameters vs Frequency

Generally speaking, the RF performance of coaxial switches is frequency dependent. With increasing frequency, VSWR and insertion loss increase while isolation decreases. All data sheets specify these three parameters as “worst case” at the highest operating frequency. If the switch is to be used over a narrow frequency band, better performance can be achieved.

Actuator Current vs Temperature

The resistance of the actuator coil varies as a function of temperature. There is an inverse relationship between the operating temperature of the switch and the actuator drive current. For switches operating at 28 VDC, the approximate actuator drive current at temperature, T, can be calculated using the equation:

$$I_T = \frac{I_A}{[1 + .00385 (T-20)]}$$

Where:

I_T = Actuator current at temperature, T

I_A = Room temperature actuator current – see data sheet

T = Temperature of interest in °C

Magnetic Sensitivity

An electro-mechanical switch can be sensitive to ferrous materials and external magnetic fields. Neighboring ferrous materials should be permitted no closer than 0.5 inches and adjacent external magnetic fields should be limited to a flux density of less than 5 Gauss.

Series Application of Multi-Throw Switches

This example shows a single-pole 9-throw unit made up of four 3-throw switches. The number of throws possible using this technique is essentially unlimited and is equal to the total number of throws available in the output stage. If a two-stage unit were set up using six position switches, the resultant would be a total of 36 outputs or a SP36T switch bank. See Figure 1.

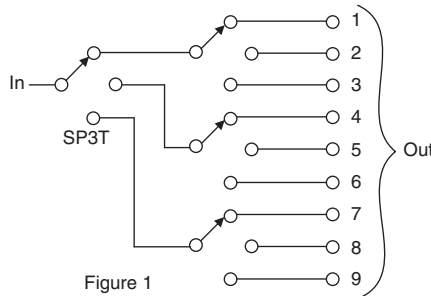

Figure 1

Transfer Switch

The transfer switch is essentially a modified double-pole-double-throw (DPDT) device. However, a true DPDT switch is a six port device that contains two totally independent transmission paths. In a transfer switch two transmission paths are provided but they are not totally independent as illustrated in Figure 2.

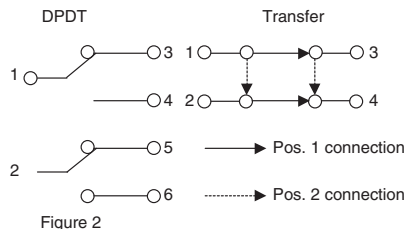

Figure 2

Examples of applications of the transfer switch are as follows:

Two Transmitters to Either of Two Antennas

Two microwave transmitters can be connected to either of two alternate antennas as shown in Figure 3.

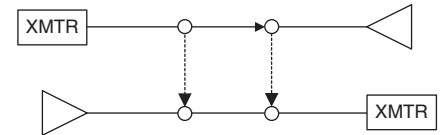

Figure 3

Circuit Insertion

A complete microwave circuit or circuit element can be inserted into a transmission line by using a transfer switch as shown in Figure 4.

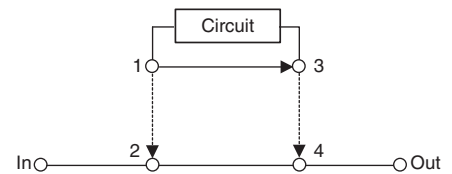

Figure 4

In the event that the 1-3 shorting of the microwave circuit is undesirable, this leg can be left out.

Special Feature

Low PIM or Highly Sensitive Signals

Ensure the most linear response with the best galvanically matched contact system in the industry. Reference tests have been done on our standard switches for Passive Intermodulation performance.

Carrier Frequency 1	Carrier Frequency 2	PIM 3rd Order Frequency	PIM 5th Order Frequency
870 MHz	893 MHz	847 MHz	824 MHz

	3rd Order Intermodulation	5th Order Intermodulation
SPDT	-91 dBm	-110 dBm
	-134 dBc	-153 dBc
Transfer	-103 dBm	-123 dBm
	-146 dBc	-165 dBc
Multiple Positions	-96 dBm	-115 dBm
	-139 dBc	-158 dBc

Microwave Switch

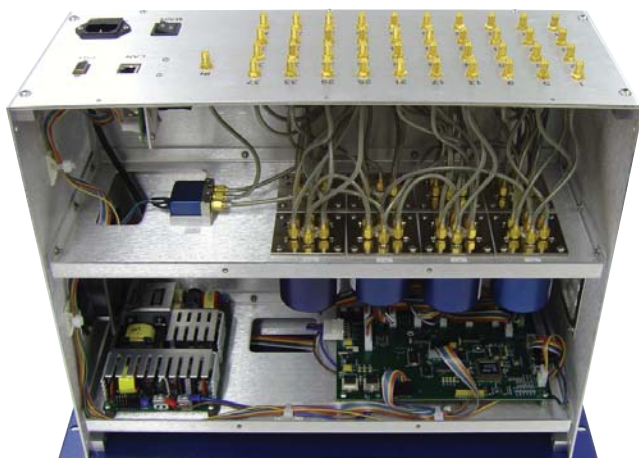
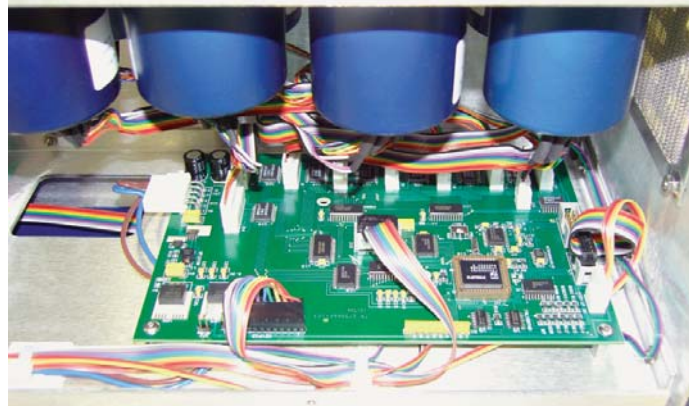

FEATURES

- Multiple standard and customized switching configurations
- Universal Power Supply
- Visual Display – LCD
- Standard and custom racks available
- Manual/direct and/or remote control
- Multiple interface configurations:
RF ports – SMA, N, SMB, TNC, etc.
Control – RS-232, Ethernet, PIO, Keypad, etc.
- 50 and 75 ohm impedances

ADDITIONAL FEATURES

- Monitor cycle count
- System health/system status
- LEDs: Visual status
- In-circuit programming (firmware upgradeable)

Matrix Assemblies



Teledyne, the world's innovative leader in manufacturing electromechanical and solid-state switching products for more than 50 years, offers a

modular approach to matrix assembly switching.

Incorporating highly repeatable and long-cycle-life relays and switches, Teledyne's matrices cover the spectrum from DC to 40GHz.



Teledyne's modular approach building matrices allows assembly of a vast array of customized matrix assemblies with the same standard subassemblies.



The internal components of the assembly and main module utilize Teledyne's proven relays and switches.

Teledyne has developed a standard programmable microcontroller that can be used for any matrix configuration. The universal power supply allows the matrix assembly to be used worldwide. Teledyne is highly vertically integrated, which reduces development time, qualification time, cost and lead time, while ensuring high quality and cost-effective production.



To learn more, call us or visit us online today. And see what Teledyne Coaxial Switches can do for you.

TYPICAL RF SWITCH PERFORMANCE

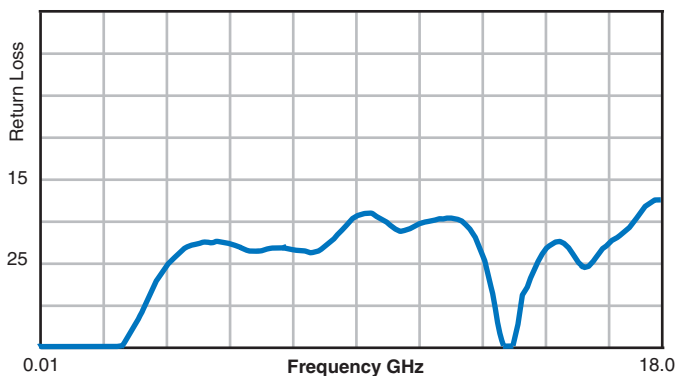
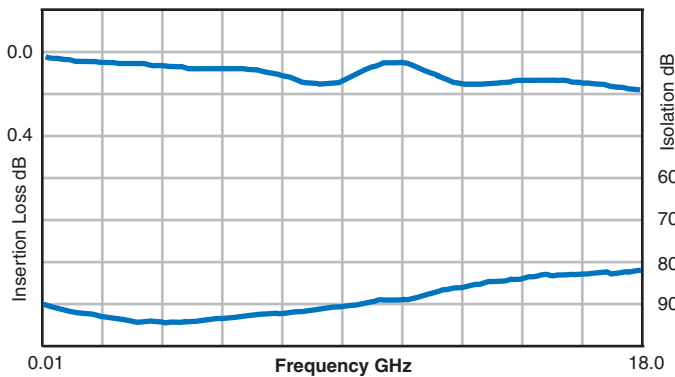

Teledyne Coax Switch Matrix



Teledyne Switch Matrices are available with a variety of RF connector types:

- SMA
- 2.92 mm
- TNC
- N
- QMA
- mini-SMB (75Ω)
- BNC (50Ω or 75Ω)

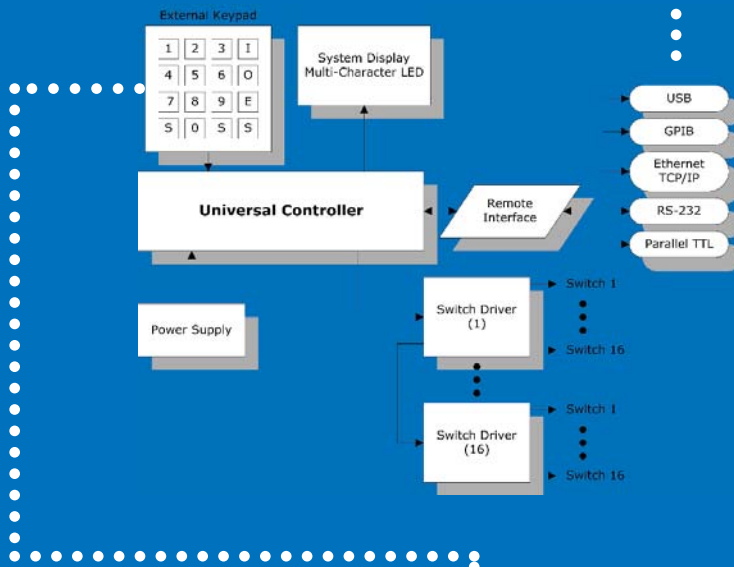

• Custom Enclosures to suit any size, mounting configuration or environmental conditions, are available.

Teledyne Switch Matrices also come in: Standard 19" Rack Mount Chassis

**Model shown is a 4U chassis. Height depends on total number of switches. Other chassis heights available upon request. (1U = 1.75" Height)*



Teledyne Switch Matrices Feature:

- Relay Switch Position Indicators
- Switch Cycle Count



PRESS RELEASE

New USB/Ethernet Controlled Miniature Switch Modules

Hawthorne, CA, July 2015: Teledyne Relays introduces the MMA, MMB & MMC series.

The MMA, MMB & MMC series is an ideal solution that incorporates Teledyne Coax Switches and remote control via USB and/or TCP/IP (Ethernet). Remote operation is accomplished via Ethernet and/or via USB virtual serial port (command set provided).

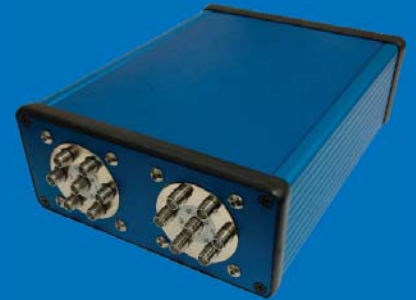

The miniature switch modules will feature a graphical user interface (GUI) that will enable the user to control switches through graphical icons and have visual indicators in addition to text-based interfaces and typed command labels.

The Series MMA will offer a maximum of 4 SPDT switches with 3 available operating frequencies: DC-18GHz, DC-26.5GHz and DC-40GHz.

The Series MMB will offer a maximum of 4 TRANSFER switches available with an operating frequency of DC-18GHz.

The Series MMC will offer a maximum of 2 SP6T (or SP5T, or SP4T or SP3T) switches with 3 available operating frequencies: DC-18GHz, DC-26.5GHz and 40GHz.

For the latest news releases, visit <http://www.teledynere relays.com/newsrelease.asp>.

Teledyne Relays, a Business Unit of Teledyne Reynolds Inc., has been the world's innovative leader in manufacturing ultraminiature, hermetically sealed, electromechanical and solid-state switching products for over 50 years. The company's comprehensive product line meets a wide range of requirements for industrial, commercial, military and aerospace applications.

Description

The MMA Series is an ideal solution that consists of SPDT, electromechanical coaxial switches designed to switch a microwave signal from a common input to either of two outputs. The characteristic impedance is 50 Ohms. The terminated option provides an impedance match for the unselected port. The MMA Series is designed to allow the remote operation of 1 to 4 Single Pole Double Throw switches. Remote operation is accomplished via TCP/IP commands to the Matrix's Ethernet interface. Switch control is also accessible via the USB virtual serial port, using the provided command set. Through these interfaces the Coax Switch can be switched to the desired position and its position can be read for verification. The default switch position at power up can be set by the user.

Options

- USB only or USB & Ethernet Control
- Terminated or Non-Terminated
- Failsafe or Latching
- Various Connectors
- Multiple Frequency Ranges

Number of Switches
1 to 4 SPDT
Switching Type
Electromechanical
Temperature
Operating: -40°C to +65°C

Additional Information	
Available Connectors	SMA, 2.92 mm, Type N, TNC
Line Power	Universal 90-260 VAC, 47-63Hz
Enclosure A Size (WxHxD)	5.08" Wide, 2.17 High, 7.75" Depth
Enclosure B Size (WxHxD) (4 Terminated SPDT)	8.00" Wide, 3.00" High, 8.00" Depth
Typical Cycle Life	5,000,000 cycles

Connector Types	Frequency Range
2.92 mm	DC - 40 GHz
SMA	DC - 26.5 GHz
Type N	DC - 12 GHz
TNC	DC - 12 GHz

ENCLOSURE DIMENSIONS

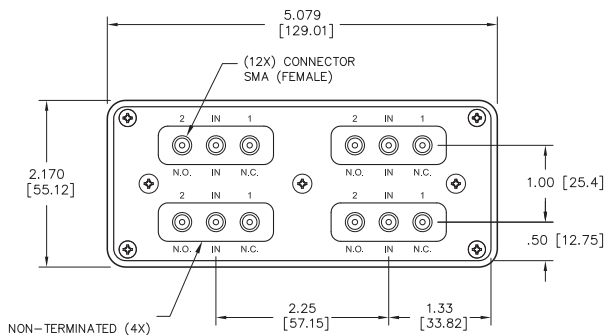

Enclosure A

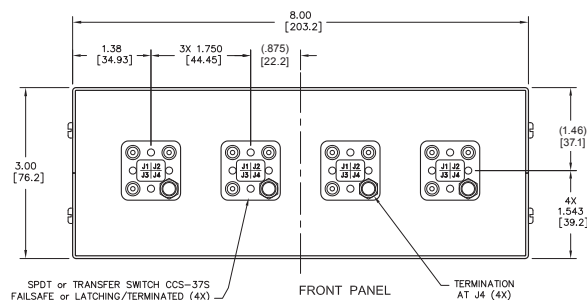

Enclosure B



ENCLOSURE A - FRONT VIEW



ENCLOSURE A - REAR VIEW

Description

The MMB Series is an ideal solution that consists of Transfer, electromechanical coaxial switches designed to switch a microwave signals in a DPDT configuration. The characteristic impedance is 50 Ohms. The MMB Series is designed to allow the remote operation of 1 to 4 Transfer switches. Remote operation is accomplished via TCP/IP commands to the Matrix's Ethernet interface. Switch control is also accessible via the USB virtual serial port, using the provided command set. Through these interfaces the Coax Switch can be switched to the desired position and its position can be read for verification. The default switch position at power up can be set by the user. The MMB will feature a graphical user interface (GUI), which will enable user to control switches through graphical icons and visuals.

Options

- USB only or USB & Ethernet Control
- Terminated or Non-Terminated
- Failsafe or Latching
- Various Connectorcs
- Multiple Frequency Ranges

Number of Switches
1 to 4 Transfer
Switching Type
Electromechanical
Temperature
Operating: -40°C to +65°C

Additional Information	
Available Connectors	SMA, Type N, TNC
Line Power	Universal 90-260 VAC, 47-63Hz
Enclosure A Size (WxHxD) (1 - 2 Transfer)	5.08" Wide, 2.17 High, 7.75" Depth
Enclosure B Size (WxHxD) (4 Transfer)	8.00" Wide, 3.00" High, 8.00" Depth
Typical Cycle Life	5,000,000 cycles

Connector Types	Frequency Range
SMA	DC - 18 GHz
Type N	DC - 12 GHz
TNC	DC - 12 GHz

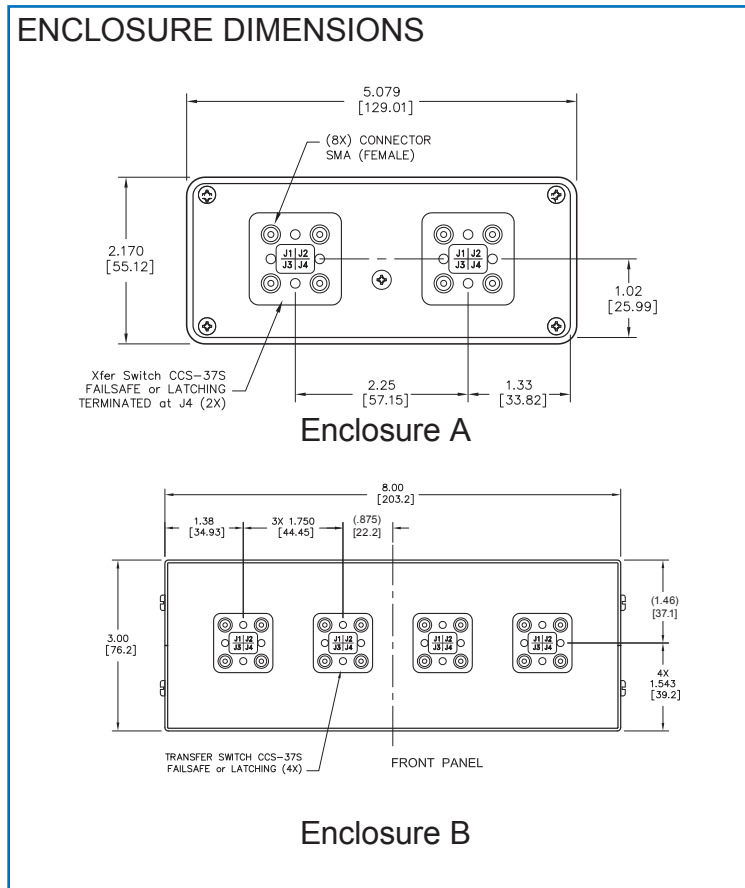

Description

The MMC Series is an ideal solution that consists of multi-throw, electromechanical coaxial switches designed to switch a microwave signal from a common input to any of 3, 4, 5, or 6 outputs. The characteristic impedance is 50 Ohms. With the normally open actuator, all paths are open when the switch is de-energized. The MMC Series is designed to allow the remote operation of 1 to 2 Single Pole Multi Throw switches. Remote operation is accomplished via TCP/IP commands to the Matrix's Ethernet interface. Switch control is also accessible via the USB virtual serial port, using the provided command set. Through these interfaces the Coax Switch can be switched to the desired position and its position can be read for verification. The default switch position at power up can be set by the user.

Options

- USB only or USB & Ethernet Control
- Terminated or Non-Terminated
- Failsafe or Latching
- Various Connectors
- Multiple Frequency Ranges

Number of Switches
1 to 2 SPMT
Switching Type
Electromechanical
Temperature
Operating: -40°C to +65°C

Additional Information	
Available Connectors	SMA, 2.92 mm, Type N, TNC
Line Power	Universal 90-260 VAC, 47-63Hz
Enclosure A Size (WxHxD) (Non-Terminated SPMT)	5.08" Wide, 2.17 High, 7.75" Depth
Enclosure B Size (WxHxD) (Terminated SPMT)	8.00" Wide, 3.00" High, 8.00" Depth
Typical Cycle Life	5,000,000 cycles

Connector Types	Frequency Range
2.92 mm	DC - 40 GHz
SMA	DC - 26.5 GHz
Type N	DC - 12 GHz
TNC	DC - 12 GHz

ENCLOSURE DIMENSIONS

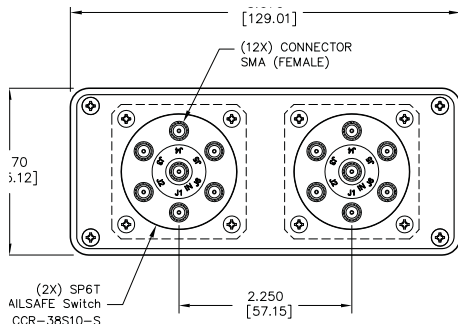

Enclosure A

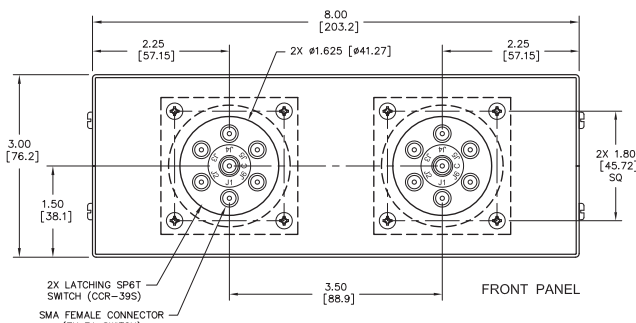

Enclosure B



ENCLOSURE A - FRONT VIEW



ENCLOSURE A - REAR VIEW

Series RF121 / GRF121

SPDT Magnetic-Latching
Up to DC-16GHz RF Relay
Signal Integrity up to 40Gbps





Series GRF121 Electromechanical Relays

The ultraminiature GRF121 relay is designed to provide a practical surface-mount switching solution with RF performance and repeatability to 16GHz. The GRF121 improves on Teledyne Relays' heritage of miniature RF relays by incorporating a precision transmission line structure in the internal construction of the contact system. GRF121 relays feature a unique ground shield to facilitate surface mounting and to extend the frequency range when compared to through-hole solutions.

- Broader bandwidth (DC - 16GHz)
- Excellent Signal integrity up to 40Gbps
- Hermetically Sealed
- High Resistance to ESD
- Metal Enclosure for EMI shielding
- High Repeatability
- 3 Million Cycle Life

Relay Type	SPDT Magnetic-Latching
Frequency Range	RF121 = DC - 12 GHz GRF121 = DC - 16 GHz
Bit Rate	RF121 = 20 Gbps GRF121 = 40 Gbps
Mounting	RF = Thru-hole GRF = Surface-Mount (Stub)
Available Coil Voltages	5V: Coil Resistance (Ω) = 61 12V: Coil Resistance (Ω) = 500
Temperature	Storage: -65°C to $+125^{\circ}\text{C}$ Operating: -55°C to $+85^{\circ}\text{C}$

Part No.	Typical RF Performance			
	Frequency (GHz)	VSWR (max)	Isolation (dB)	Insertion Loss (dB) (max)
 RF121	DC - 4	1.3 : 1	55	0.25
	4 - 8	1.50 : 1	50	0.45
	8 - 12	2.0 : 1	40	1.35
 GRF121	DC - 4	1.1 : 1	65	0.2
	4 - 8	1.20 : 1	50	0.2
	8 - 12	1.35 : 1	40	0.5
	12 - 16	2.0 : 1	30	0.95

RF121 : 20 Gbps

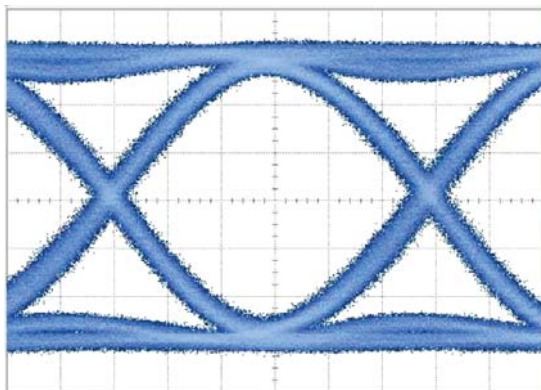

Bit Rate	Eye Height	Eye Width	Jitter _{P-P}
20 Gbps	360 mV	40.3 ps	6.93 ps

PATTERN GENERATOR SETTINGS

- 20 Gbps Random Pulse Pattern Generator
- $2^{31} - 1$ PRBS signal
- PRBS output of 500 mV_{P-P} (nominal)
- RF PCB effect (negligible) not removed from measurement
- Data shown is typical of both contacts

GRF121 : 40 Gbps

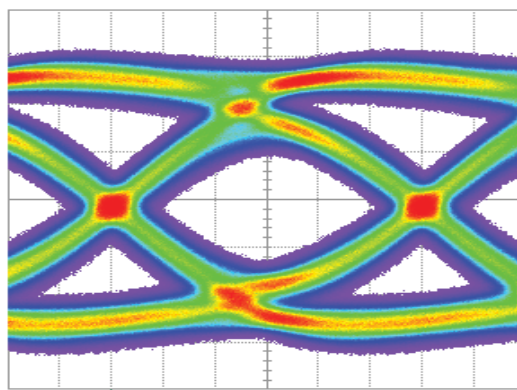

Bit Rate	Eye Height	Eye Width	Jitter _{P-P}
40 Gbps	95 mV	13.34 ps	8.73 ps

PATTERN GENERATOR SETTINGS

- 40 Gbps Random Pulse Pattern Generator
- $2^{31} - 1$ PRBS signal
- PRBS output of 500 mV_{P-P} (nominal)
- RF PCB effect (negligible) not removed from measurement
- Data shown is typical of both poles

Teledyne Relays offers electromechanical relays for various markets?

RF RELAYS

- Signal Integrity up to 40Gbps
- DC - 16GHz
- Surface-Mount
- DPDT, SPDT, 4PST and Loopback Relays



MILITARY GRADE RELAYS

- Built and tested to meet MIL-PRF-39016
- Built and tested to meet MIL-PRF-28776
- Built-in Diodes, Transistor Driver and CMOS
- Low Power coils



TELEDYNE ESTABLISHED RELIABILITY RELAYS

- Fully defined product requirements and screening levels
- Spacer/Spreader pad options not allowed by military specifications
- Reduced lead time and cost vs Military Grade



HIGH PERFORMANCE RELAYS

- -65° C to +200° C
- Shock up to 4,000 g's
- Vibration up to 380 g's
- Non-Latching & Magnetic-Latching



COMMERCIAL RELAYS

- Standard electrical tests at 25° C
- "Low cost" switching solutions
- Surface-Mount
- Short lead times



Did you know...

Teledyne Coax Switches offers coaxial switches for ATE, Radar, Amplifier Switching, Etc.?

SPDT SWITCHES

- DC - 40GHz, Internal 50Ω Termination
- SMA, mini-SMB, TNC & N Connectors
- 5 Million Cycles
- High Power & Low PIM
- Failsafe & Latching



TRANSFER SWITCHES

- DC - 18GHz
- SMA, TNC & N Connectors
- 5 Million Cycles
- High Power
- Failsafe & Latching



MULTI-THROW SWITCHES

- DC - 40 GHz, Internal 50Ω Termination
- SMA, mini-SMB, TNC & N Connectors
- SP3T - SP10T
- 5 Million Cycles
- Normally Open & Latching



LOW PIM SWITCHES

- DC - 3 GHz
- SMA, N and 7/16 D Connectors
- SPDT, Transfer and Multi-Throw
- Failsafe & Latching



SPECIALTY SWITCHES

- DC - 40GHz
- 3-State Attenuated Switch
- Radiation Shielding
- Switch Blocks
- Redundant Diode Configuration



Teledyne Relays offers Commercial/Industrial Solid State Relays?

SINGLE PHASE AC SOLID STATE RELAYS

- Up to 690Vac, 125A
- Input & Output Protection
- Chassis, DIN Rail and PCB Mount
- Zero-Cross & Random Switching
- Touch-Proof Covers



DUAL-PHASE AC SOLID STATE RELAYS

- Up to 600Vac, 50A
- Output Protection
- Chassis and DIN Rail
- Zero-Cross & Random Switching
- Touch-Proof Covers



3 & 4 PHASE SOLID STATE RELAYS

- Up to 600Vac, 75A
- Output Protection
- Chassis and DIN Rail
- Zero-Cross & Random Switching
- DC & AC Control

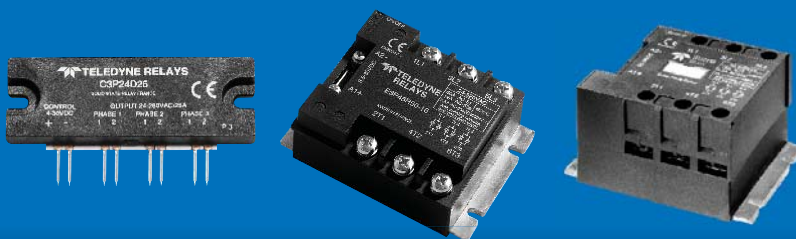

DC SOLID STATE RELAYS

- Up to 1400Vdc, 100A
- Output Protection
- Chassis, DIN Rail and PCB Mount
- IGBT and MOSFET
- Touch-Proof Covers



SOFT START MOTOR CONTROLLERS AND MOTOR REVERSERS

- Up to 26kW, 480Vac
- Star & Delta Configurations
- DIN Rail
- Output Protection
- Built-in Diagnostics and Self Test



Did you know...

Teledyne Relays offers Military Solid State Relays?

DC SOLID STATE RELAYS

- Meet MIL-PRF-28750
- Tested Per MIL-STD-704
- Silicon Carbide MOSFET
- Up to 250Vdc, 1A
- Chassis and PCB Mount
- Short-Circuit Protection
- Plastic and Hermetically Sealed



BI-DIRECTIONAL/AC SOLID STATE RELAYS

- Meet MIL-PRF-28750
- Tested Per MIL-STD-704
- Up to 250Vac, 25A
- Chassis and PCB Mount
- Short-Circuit Protection
- Plastic and Hermetically Sealed

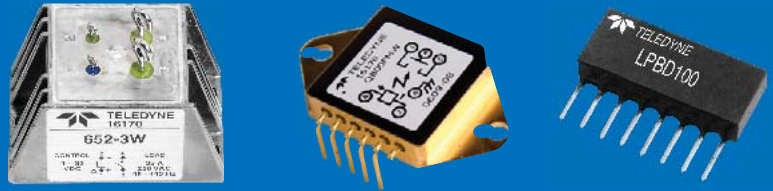

COMMERCIAL, LOW POWER, I/O MODULES

- Up to 250Vac, 10A
- Short-Circuit Protection
- Chassis and PCB Mount
- Zero-Cross & Random Switching
- Low Off-State Leakage Current



SILICON CARBIDE TECHNOLOGY

- Up to 270Vdc, 20 A
- Meet MIL-PRF-28750
- Tested Per MIL-STD-704
- Low ON resistance
- Low Profile Hermetic Package



Did you know...

Teledyne Coax Switches offers coaxial switch matrices for ATE, Radar, Filter Switching, Airborne Surveillance Systems, Etc.?

MINI MATRICES

- Remote Control via USB and/or Ethernet
- GUI controllable
- Accepts ASCII code
- Available in 18, 26.5 and 40 GHz
- SPDT, Transfer and Multi-throw configurations



MULTIPLEXOR/FANOUT SWITCH MATRICES

- Up to 1x1024 Switch Matrix
- SMA, mini-SMB, TNC & N Connectors
- Failsafe, Latching or Normally Open Configurations
- Switching Systems for 50Ω & 75Ω applications

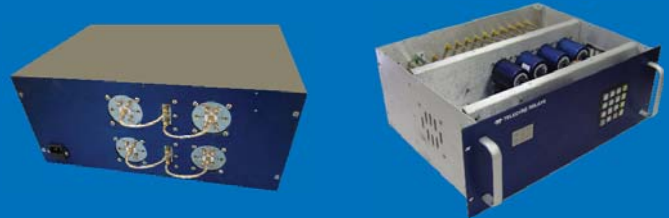

MIMO/BLOCKING AND MIMO SINGLE CONNECTION SWITCH MATRICES

- Up to 1x1024 Switch Matrix
- SMA, mini-SMB, TNC & N Connectors
- RS-232, TTL, USB, GPIB, TTL, Ethernet Control
- 1 Million Cycles
- Failsafe & Latching



CUSTOMIZED SWITCH MATRICES

- EMI/RFI
- Transient Suppression
- Ballistic Shock Fatigue
- Crash Load
- Altitude



Did you know...

Teledyne Relays offers Space Qualified Switches?

SPACE MARKET SEGMENTS SERVED

- Deep-Space Probes
- Manned Programs
- Communications Satellites
- Launch Vehicles
- Earth Observatory / Weather Satellites
- Commercial / Military Satellites



CAPABILITIES

- Logistic Infrastructure
- Chemical Analysis Lab
- Scanning Electro Microscope
- In-house Plating Shop
- Environment Test Lab
- Field Technical Support



ELECTROMECHANICAL RELAY SPECIFICATIONS

- MIL-PRF-39016
- MIL-PRF-28776
- NASA/GSFC S-311-P-754
- NASA EEE-INST-002
- ESA/SCC 3601 & 3602



HEADQUARTERS

12525 Daphne Ave.
Hawthorne, CA 90250
Phone: (323) 777-0077 or (800) 351-7368
Fax: (323) 241-1287
E-mail: coax@teledyne.com

www.teledynecoax.com
(800) 351-7368

EUROPE

9-13 Napier Road
Wardpark North
Cumbernauld G68 OEF
Scotland UK
Phone: +44 (0) 1236 453 124
Fax: +44 (0) 1236 780 651
E-mail: sales_europe@teledyne.com

www.teledyne-europe.com
+44 (0) 1236 453 124



TELEDYNE
COAX SWITCHES
Everywhereyoulook™